



# Creativity Art and Innovation



Blue Mountain 22"x28" Oil

## A body of work by David Copplestone

A lifetime of;  
HOPES, THOUGHTS, DREAMS, and IDEAS

## Introduction

Welcome to today's exhibit: MOMENTS  
By: David Wesley Coplestone



© 1975 - 2020 by David W. Coplestone

### Moments

It is my goal to capture in these paintings some of the infinite moments we share that define our lives. The paintings depict the activities or scenes any one of us might participate in or lend our attention to on any given day. Using line and color as my tools, I give these common experiences my unique and colorful interpretation.

This art project is limitless and I will do only my share of the series, linked with the artists who have come before me and those who will come after. I hope my efforts are worthy of a place in that line, and that in my race with time I use my moments wisely.

David W. Coplestone graduated from The Art Institute Of Boston in 1975.  
Wellesley, MA 02482, Osterville, MA 02655

[coplestoneartworks.com](http://coplestoneartworks.com)

# Chapter One

Artwork by: David Wesley Copplestone



1. Starbucks 24" x 36" Oil



2. Ocean view 24" x 36" Oil

"If thou follow thy star, thou canst not fail of a glorious heaven."  
Dante Aligheri



3. Bass Rocks Three, 18"x24" oil



4. Yesterday and Today 24" x 36" Oil

"The most exciting phrase to hear in science, the one that heralds new discoveries, is not 'Eureka!' (I found it!) but 'That's funny ... '" - Isaac Asimov (1920-1992)



5. Sea View 24"x36" oil



6. Bass Rocks 2 18" x 24" Oil

"The adventure of the sun is the greatest natural drama by which we live."  
- Henry Beston



7. Cloud Passing 16" x 20" Oil



8. Orange Windows 24" x 36" Oil

"There is a theory which states that if everybody discovers exactly what the Universe is for and why it is here, it will instantly disappear and be replaced by something even more bizarre and inexplicable. There is another theory which states that this has already happened."  
Douglas Adams



9. Arno Villa 16" x 24" Oil



10. Red Tree on a Hill 24" x 36" Oil

"There are many things that are known and things that are unknown; in between is exploration." Anonymous



11. Horseback Ride at Hampton Beach 24" x 36" Oil

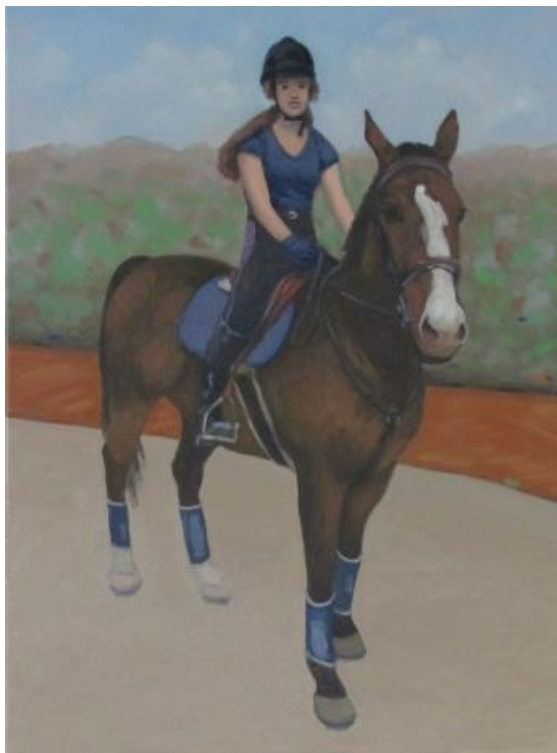

12. Roscoe and Rider, 18"x24" oil

The universe is moved by power which cycles endlessly from day to day. Such greatness endures for all time.  
As in heaven, so on earth."  
-I. Ching (B.C. ii50?)



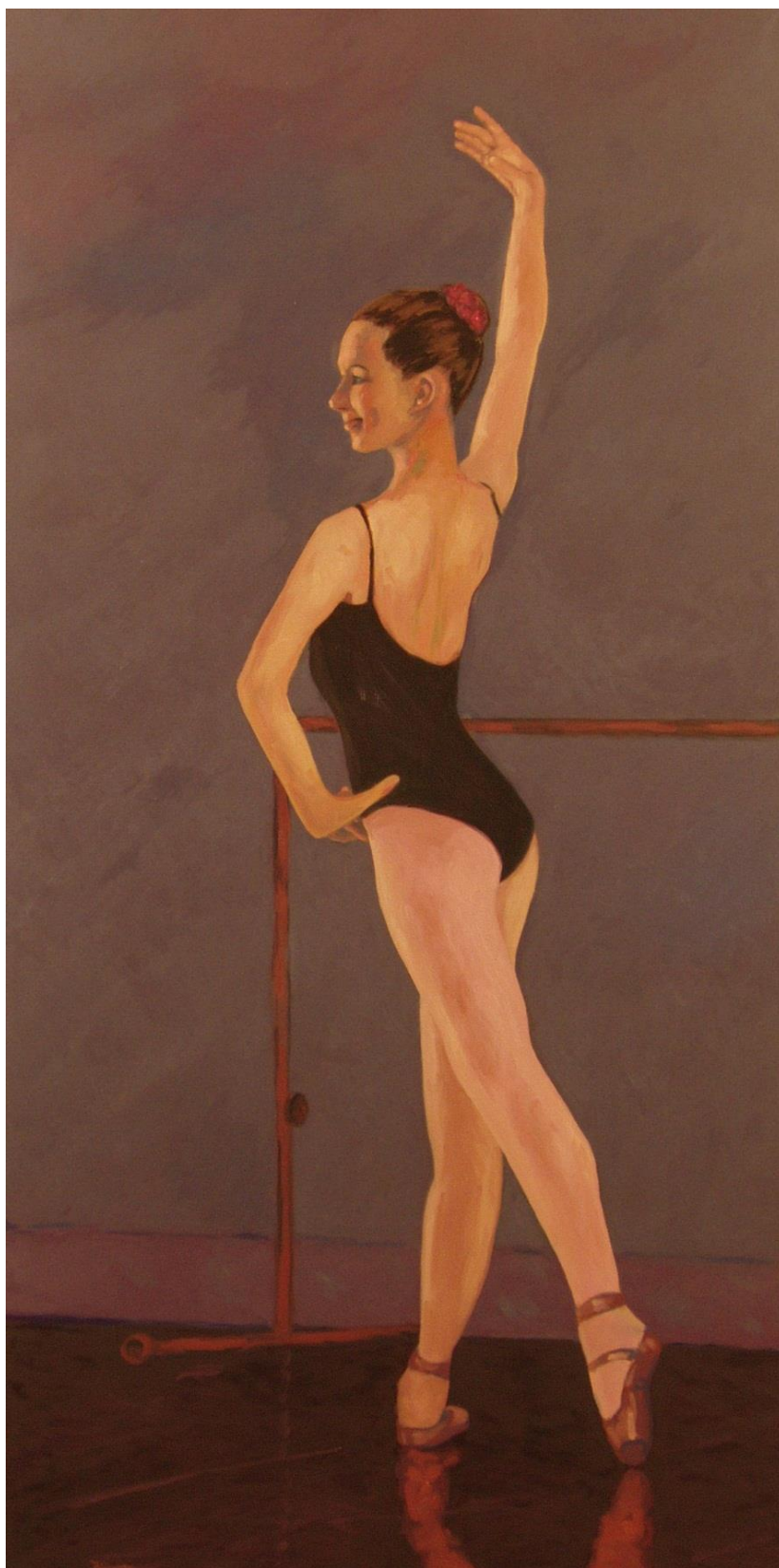

13. Charlotte #2 24" x 48" Oil

"Man hath weaved out a net, and this net thrown upon the Heavens, and now they are his own."  
-.John Donne (1572-1631)

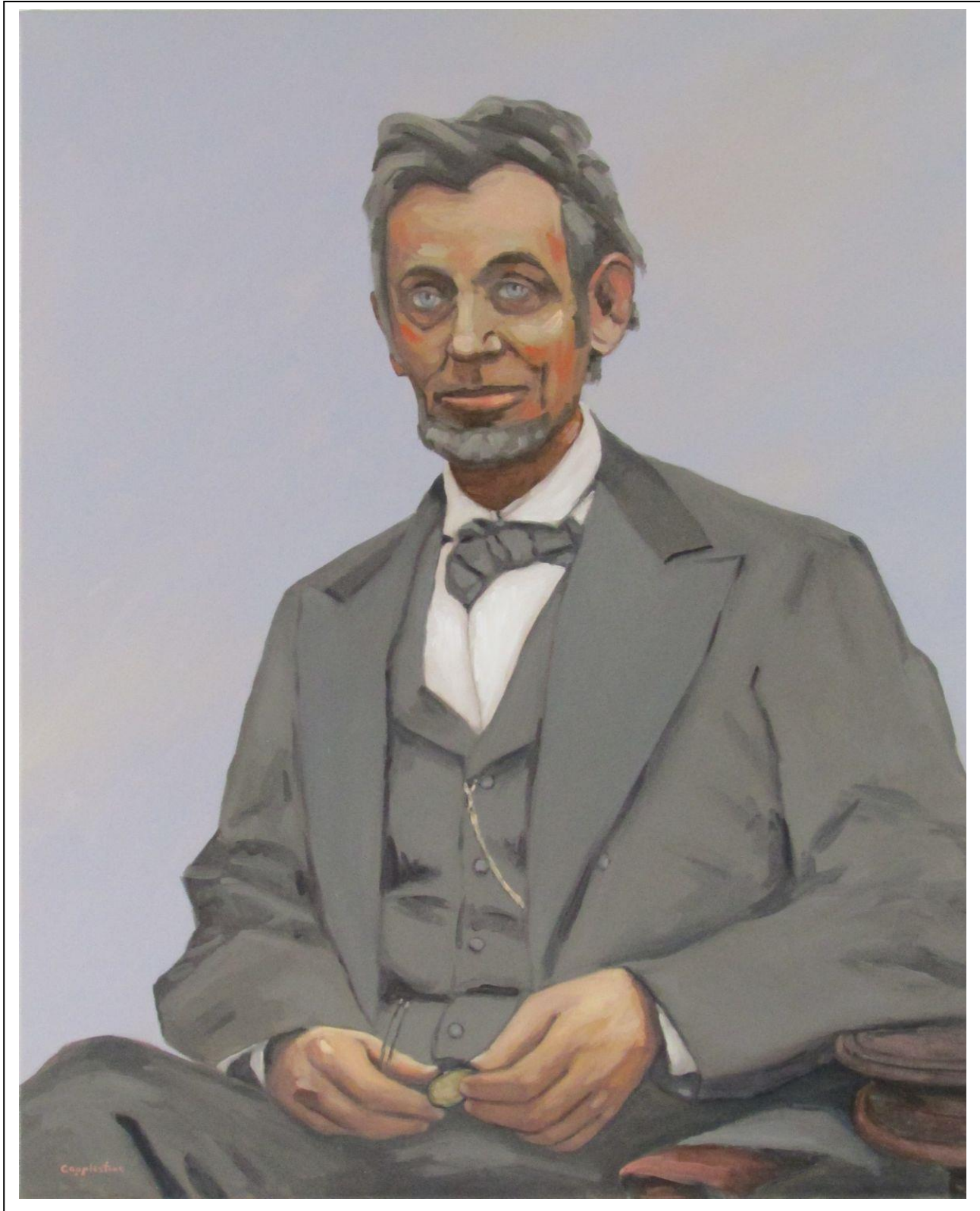

14. Wisdom – Abraham Lincoln 24” x 30” Oil

“Four score and seven years ago our fathers brought forth on this continent, a new nation, conceived in Liberty, and dedicated to the proposition that all men are created equal.” – November 19, 1863 – Lincoln’s Gettysburg Address



15. Ballet Students 18"x24" oil



16. Sarah in blue hat 20" x 24" Oil



17. What Dream Is This The Answer To? 24" x 36" Oil



18. Why? 16" x 20" Oil

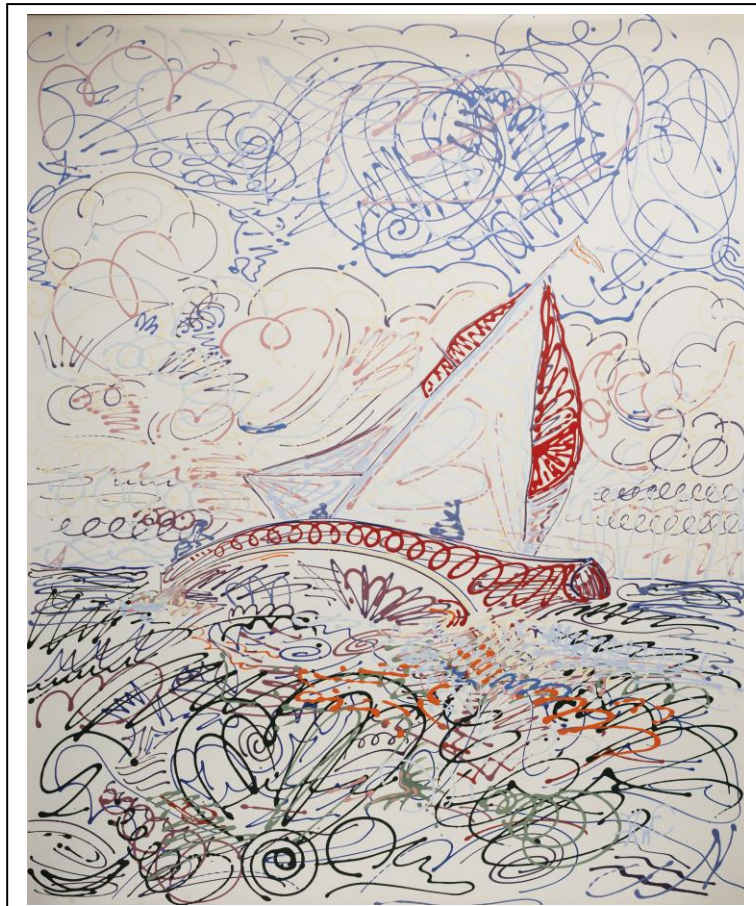

19. Sloop 48" x 60" Latex



20. Road Home 24" x 30" Oil

"Ye stars! Which are the poetry of heaven!" -Lord Byron (1788-1824)

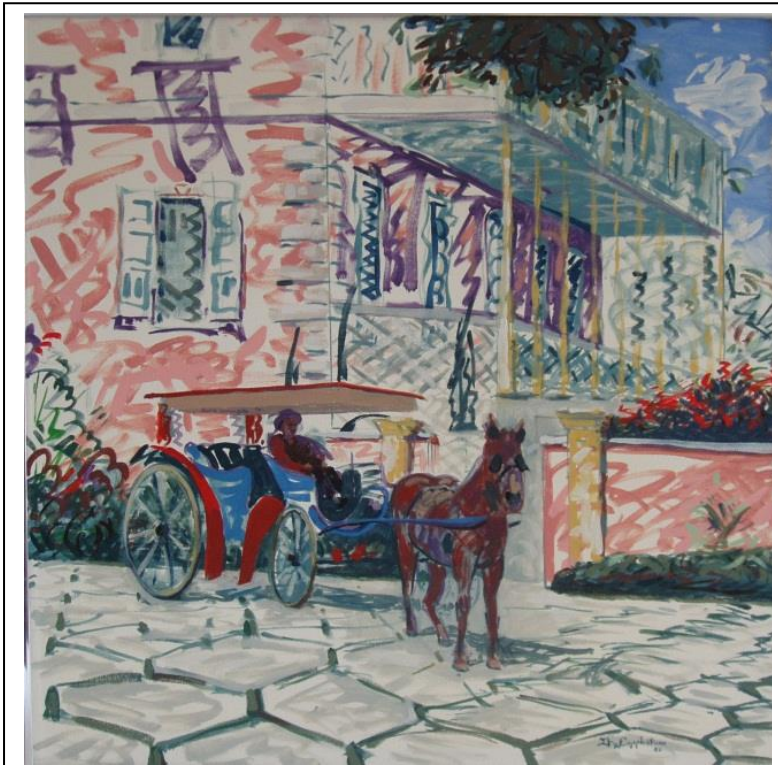

21. Bermuda Carrige 30" x 30" Oil



22. Violin Player 24" x 30" Oil

If a man will begin with certainties, he shall end in doubts; but if he will be content to begin with doubts, he shall end in certainties. -Francis Bacon



23. Lookout Farm 24" x 36" Oil



24. Outside the Coliseum 24" x 36" Oil

Today gives us a chance to love, to play, and to look up at the stars.  
Henry Van Dyke



25. Dad's Shoes – Hannah 20" x 24" Oil



26. Lake Road 18"x24" Oil

"Man hath weaved out a net, and this net throwne upon the Heavens, and now they are his own."  
-.John Donne (1572-1631)





27. Hannah on the Stairs 24" x 36"



28. Ponte Vecchio 24" x 36" Oil

It is sufficiently clear that all things are changed, and nothing really perishes, and that the sum of matter remains absolutely the same. -Francis Bacon, *De Natura Rerum*



29. Gloucester dry dock 24" x 36" Oil

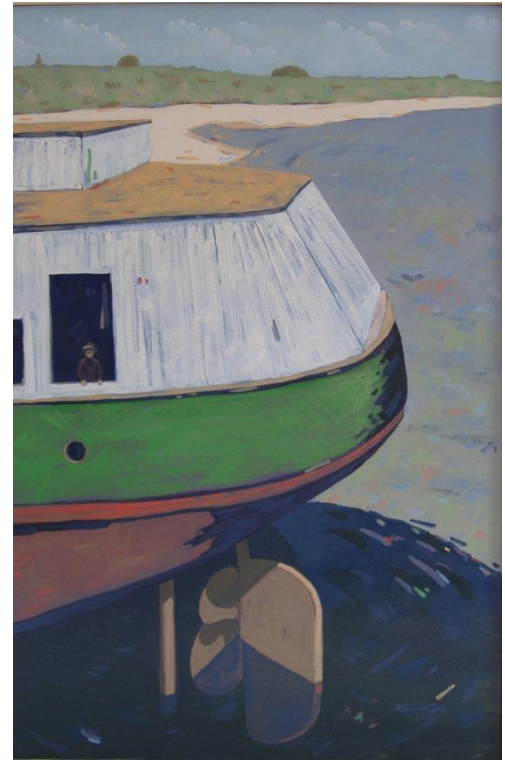

30. Beached 24" x 36" Oil



31. Couple Planning 24" x 36" Oil

Make no little plans: they have no magic to stir men's blood . . . make big plans, aim high in hope and work. - Daniel H. Burnham

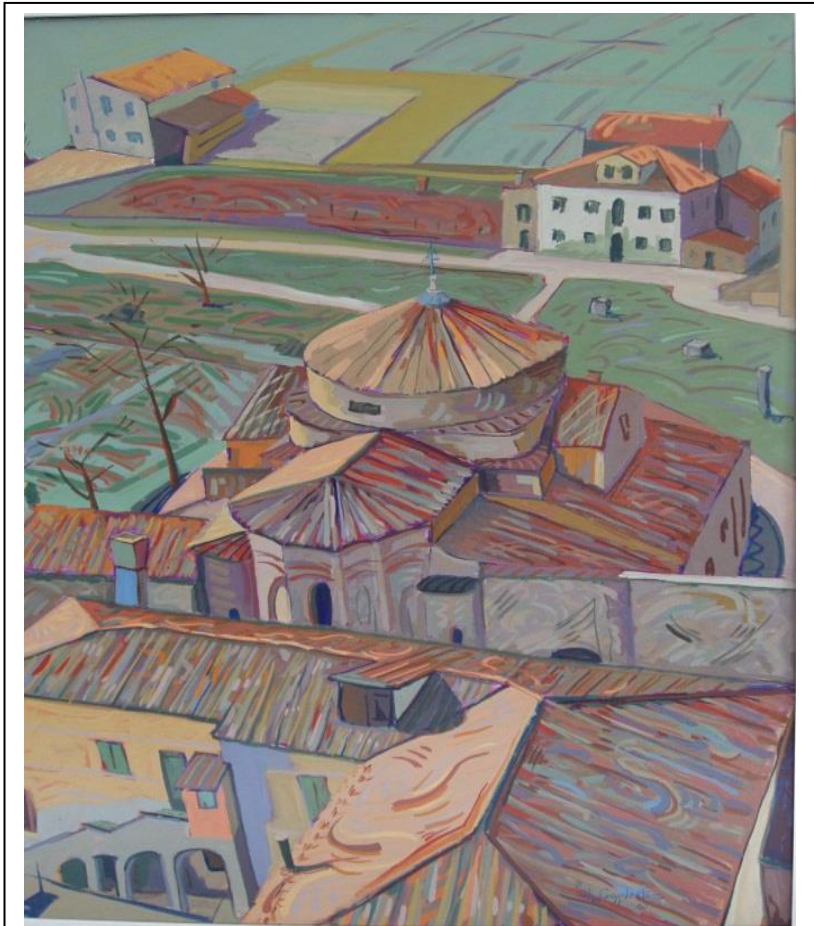

32. Rooftops 30" x 40" Oil



33. Sunnyside 20" x 30" Oil

"If the doors of perception were cleansed, everything would appear to man as it is, infinite."

-William Blake (1757-1827)



34. Gamberaia 16" x 20" Oil



35. Wain St. Cottage 16" x 20" Oil

One joy dispels a hundred cares. -Confucius

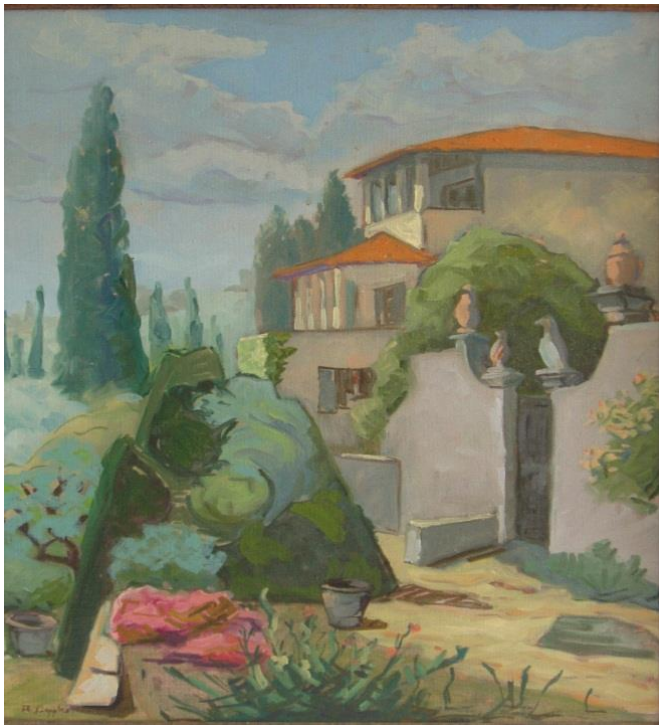

36. Courtyard 20" x 24" Oil

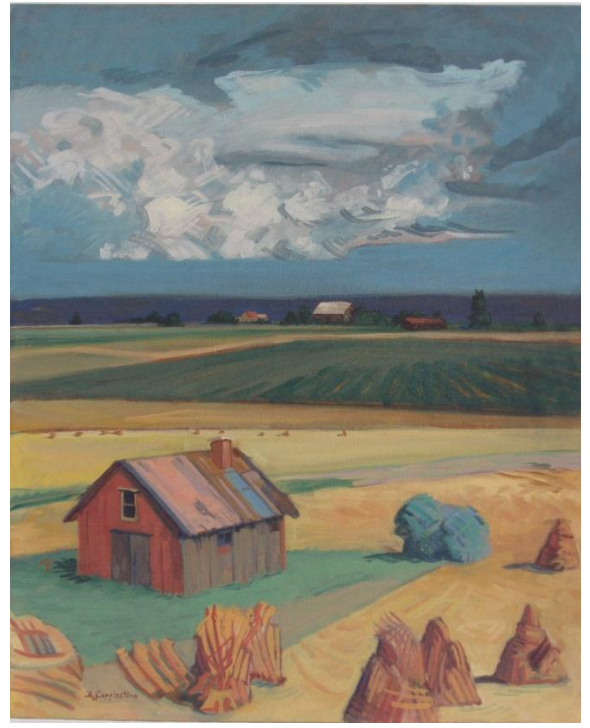

37. Thunderheads 16" x 24" Oil



38. Four Notes 24" x 36" Oil

The superior man thinks always of virtue; the common man thinks of comfort. -Confucius



39. Reformation – Ali 24" x 48" Oil

"Multiculturalism should not mean that we tolerate another culture's intolerance."  
Ayaan Hirsi Ali

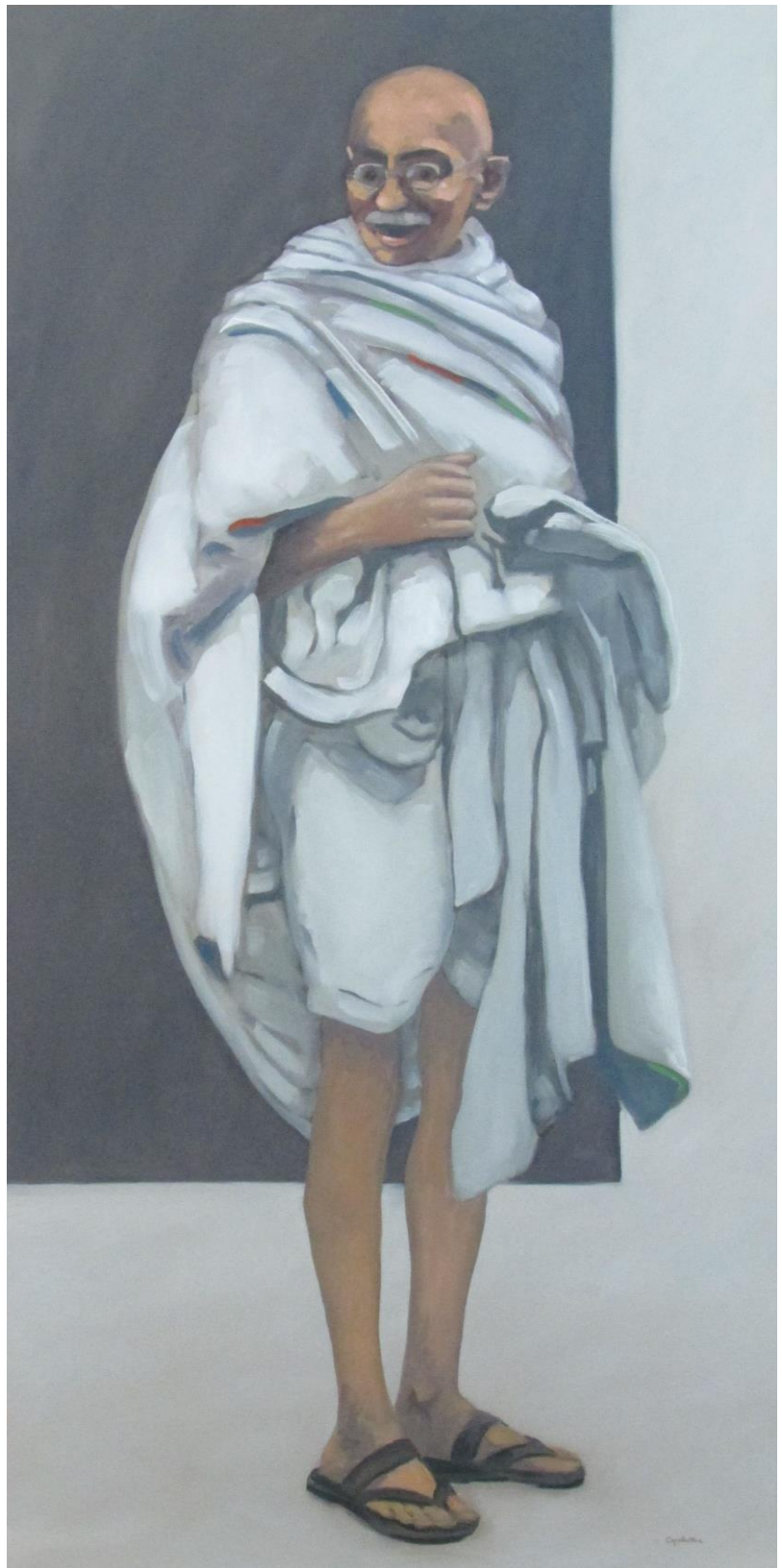

40. A Stand for Freedom - Gandhi 24" x 48" Oil

I object to violence because when it appears to do good, the good is only temporary; the evil it does is permanent.  
Mahatma Gandhi



41. Liberty 24" x 48" Oil

Freedom of The Individual from interference or coercion by other Individuals in the enjoyment of his unalienable rights and of the supporting rights. The American Ideal of 1776





42. Margaret 24" x 36" Oil



43. Self Portrait 24"x36"



44. Sarah Red Dress 24" x 36" Oil



45. Girl with Golf Club 30" x 40" Oil

"As marvelous as the stars is the mind of the person who studies them. "  
-Martin Luther King Jr.

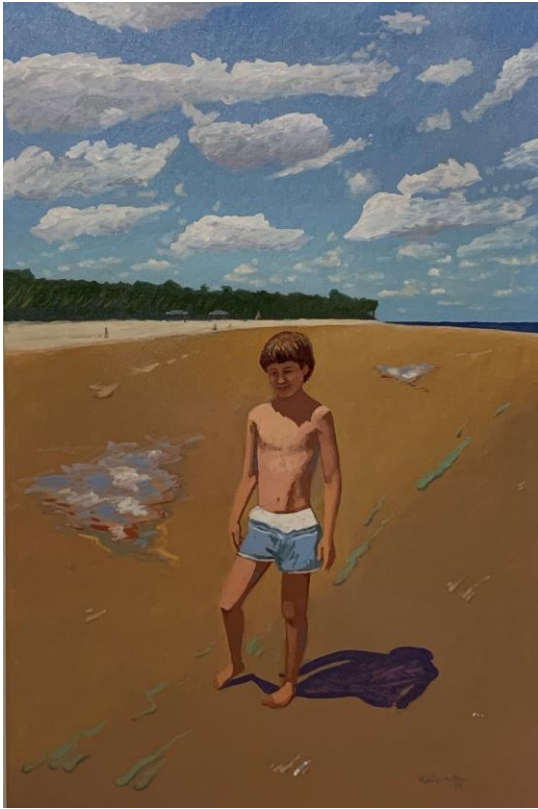

46. Jeekyll Island 24 x 36" Oil

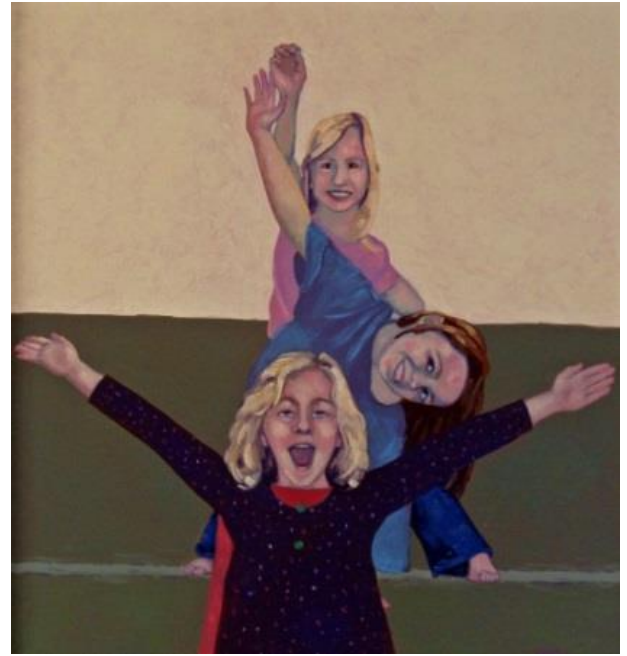

47. Joy of Being Seven 30" x 30" Oil



48. Rooftops 30" x 40" Oil



49. Sarah 24" x 36" Oil

II You do not receive an education any more than you receive a meal.  
You seek it, order or prepare it, and assimilate and digest it for yourself. II  
-Frank H. T. Rhodes



50. Hannah – Ready 2 Ride 24"x48" Oil



51. My Beauties 24"x36" Oil



52. Sunnyside 20"x30" Oil

"You and I a flesh and blood, but we are also stardust." -Helena Curtis, on the formation of the earth, *Biology*, 1968



53. Two Statues 24" x 36" Oil



54. Villa Gorzoni 24" x 36" Oil

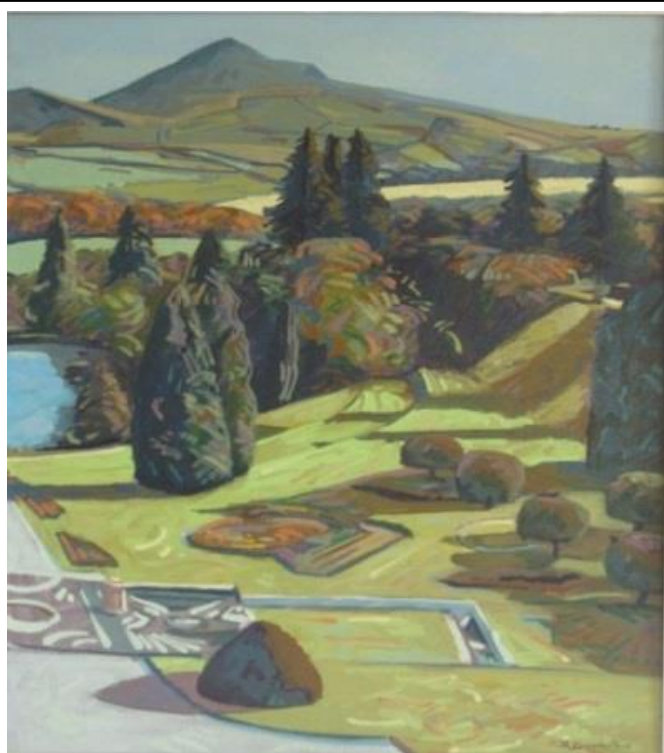

55. Blue Mountain 24" x 30" Oil



56. Street Shadows 12" x 16" Oil

"Ah, but a man's reach should exceed his grasp, or what's a heaven for?"  
Robert Browning (1812-1889)



57. Winter Harbor 16"x24" Oil

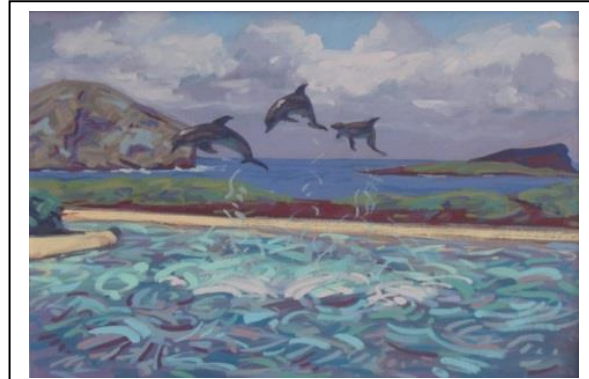

58. Three Brothers 16"x24" Oil

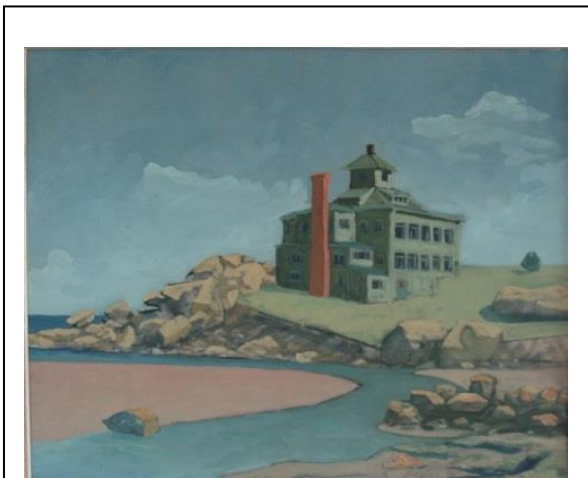

59. Bass Rocks 24"x30" Oil

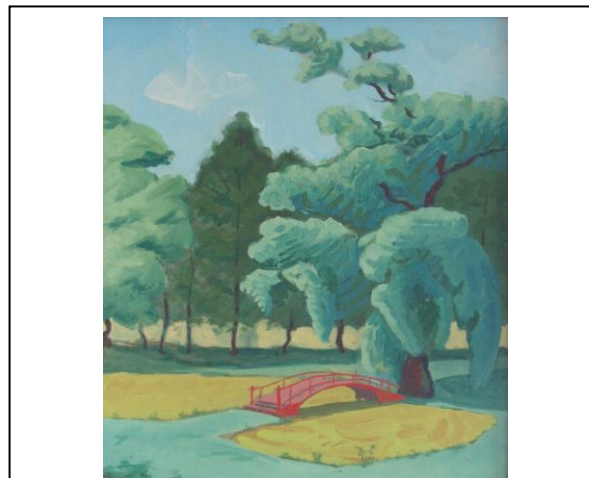

60. Red Bridge

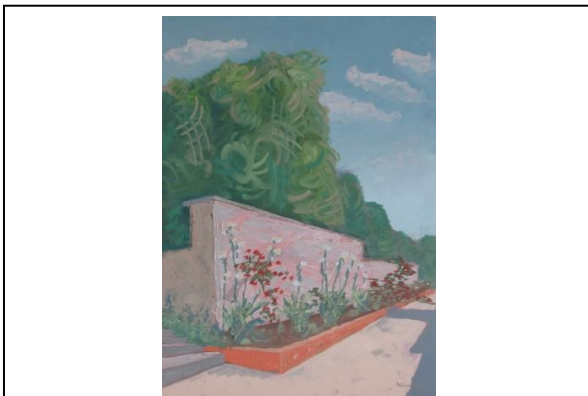

61. Warm Afternoon 20"x30" Oil



62. Swan Fountain 24"x36" Oil

"We are just strings of quarks living in a suburb of the local density maximum of the universe."  
-John D. Barrow



63. Harvard Boathouse 24" 36" Oil



64. Circle Drive 24" x 36" Oil



65. Bettie 20"x20" Oil



66. Future / Past 22" x 28" Oil Oil



67. Towers 22" x28" Oil



68. Winter Cottages 18"x24" Oil

True philosophers who are burning with love for truth and learning never see themselves . . . as wise man, brim- full of knowledge . . . For most of them would admit that even the very greatest number of things of which we know is only equal to the very smallest fraction of things of which we are ignorant. Nor are these philosophers so addicted to any kind of tradition or doctrine that they suffer themselves to become their slaves, and thus lose their liberty. -William Harvey



69. Ballarina 2 30"x30 " Oil



70. Sand pile 24" x 36" Oil



71. M d'Orsay 24"x36"Oil



72. Muerte 24"x48" Oil



73. Reflection 18"x20" Oil

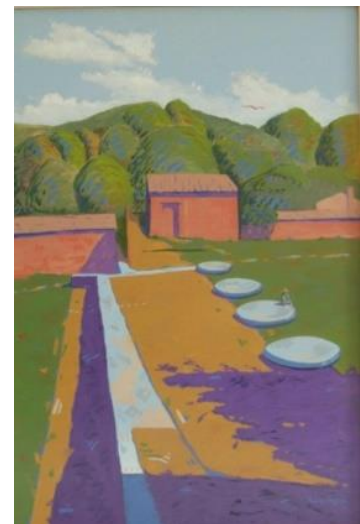

74. Vincent 24"x36" Oil

Always listen to experts. They're tell you what can't be done and why. Then do it. -Robert Heinlen



75. Maine Hillside 20"x24" Oil



76. Creator Lake 15"x30" Oil



78. White Lace 24"x30" Oil



77. Rock Ridge 24"x36" oil



79. Elephant Show 24"x36" Oil



80. Gram & Grandchildren 30"x40" oil

Hitch your wagon to a star. Let us not fag in paltry works which serve our pot and bag alone. Let us not lie and steal. No god will help. We shall find all their teams going the other way: every god will leave us. Work rather for those interests which the divinities honor and promote, --justice, love, freedom, knowledge, utility. -Ralph Waldo Emerson, *Society and Solitude* "Civilization"





81. Essex Clammers 24"x36"  
Oil



82. Blue Glass 18"x24" Oil



83. A Youthful Proposal  
16"x20" Oil

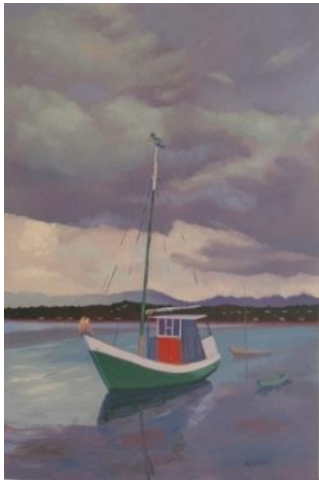

84. Pellican 24"x30" Oil



85. Burano Venice 18"x24" Oil



86. Arles Street Corner  
24"x36" Oil



87. Where 24"x48" Oil



88. United Nations 12"x24" Oil



89. Jess with Pail 24"x36"  
Oil

II You do not receive an education any more than you receive a meal.  
You seek it, order or prepare it, and assimilate and digest it for yourself. II  
-Frank H. T. Rhodes



90. Ballerina 24"x30" Oil



91. Chardin 18" x 24" Oil



92. Window Shopping 24"x36" Oil



93. St. Pierre 24"x36" Oil



94. Red White and Blue 36"x48" Oil



95. Alburnus 20"x30" Oil

"Life begins perpetually .... Life, forever dying to be born afresh, forever young and eager, will presently stand upon this earth as upon a footstool, and stretch out its realm amidst the stars."

-H. G. Wells (1866-1946)



96. The Hurdler 36"x60" Oil



97. Old Mill 24"x30" Oil



98. Green Chair 24"x30" Oil



99. Scream 18"x24" Oil



100. The Opera 24"x48" Oil

"When you get to the end of your rope, tie a knot, hang on and swing." –Unknown



101. Marianne 24"x36" Oil

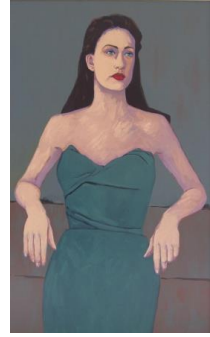

102. Madeleine 24"x36" Oil



103. Mother and Child 24"x36" Oil



104. Margerite 24"x36" Oil



105. PTowne 36"x48" Oil



106. Grand Tetons 18"x24" Oil

"We shall not cease from exploration, and the end of all our exploring will be to arrive where we started and know the place for the first time. "

-T. S. Eliot



107. Red White and Blue 24"x36" Oil

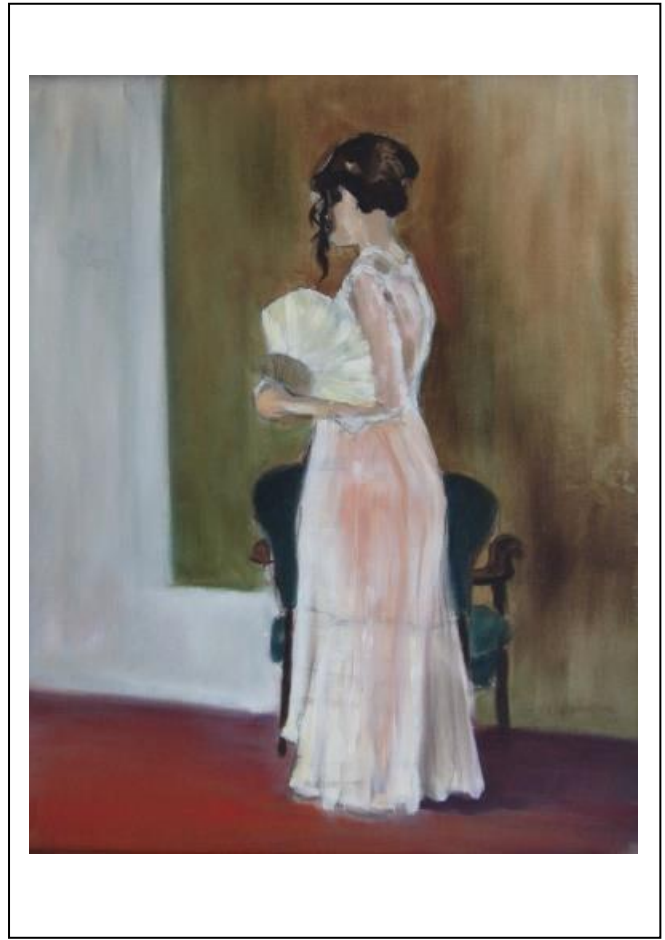

108. White Fan 24" x 36" Oil



109. Andean Bulrushes 20x24 Oil



110. Venice Gondola 20" x 24" Oil

Constancy is the foundation of virtues. -Francis Bacon, *De Augmentia Scientiarum*

# Designs Airships

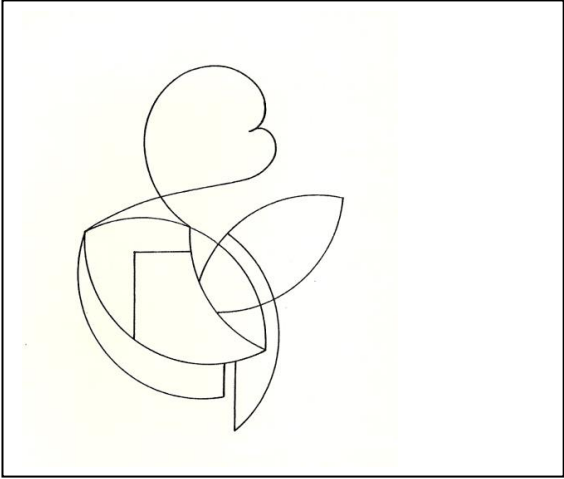

001. dwc1971-001-a

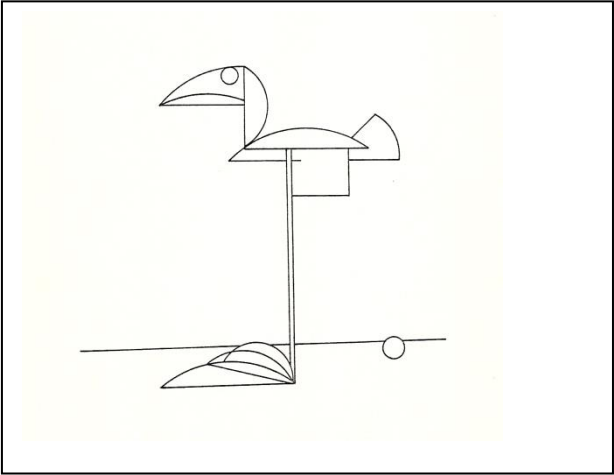

002. dwc1971-002-a

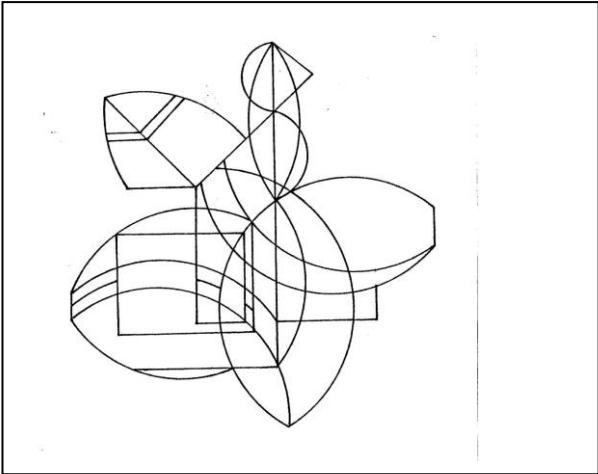

003. dwc1971-003-a

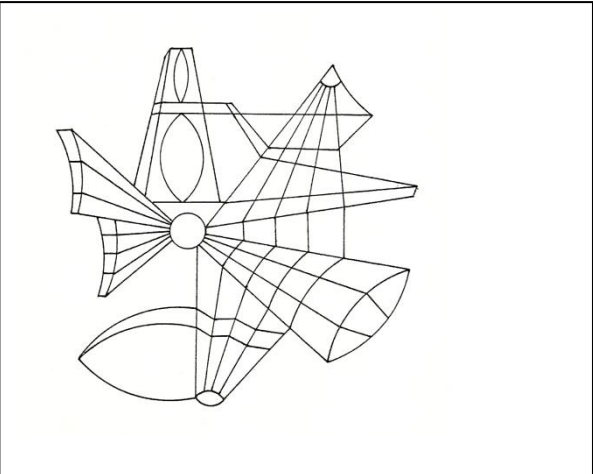

004. dwc1971-004-a

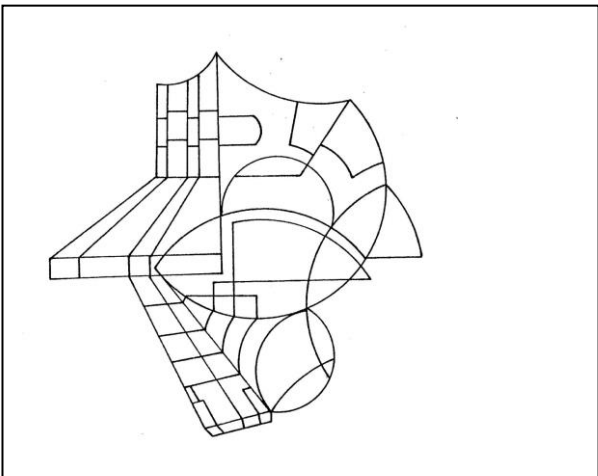

005. dwc1971-005-a

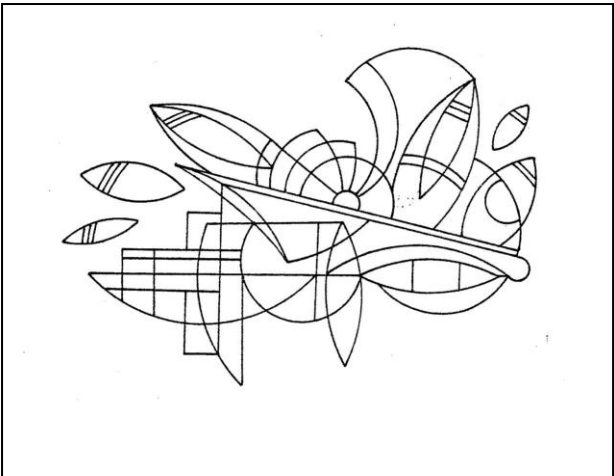

006. dwc1071-006-a

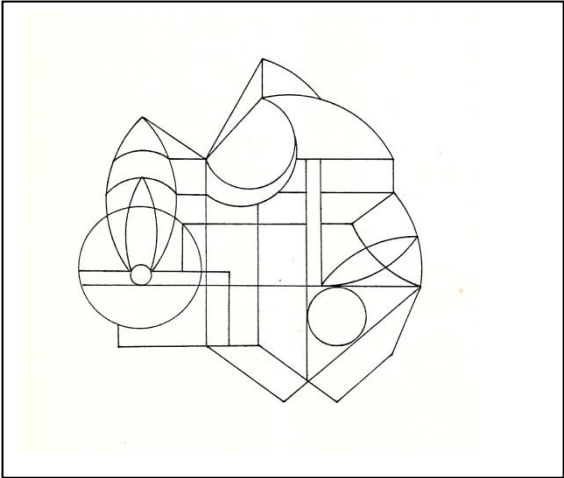

007. dwc1971-007-a

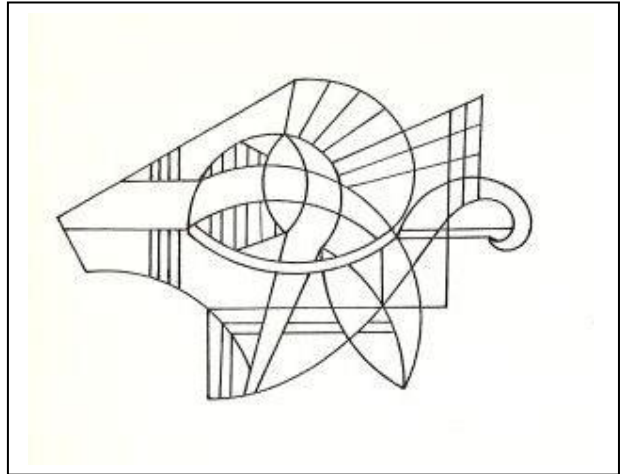

008. Dwc1971-008-a

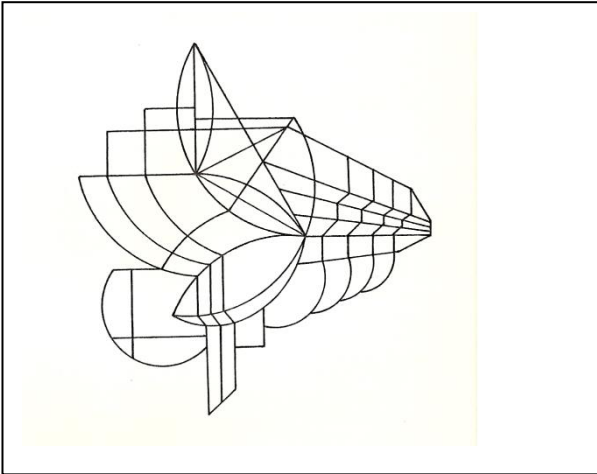

009. dwc1971-009-a

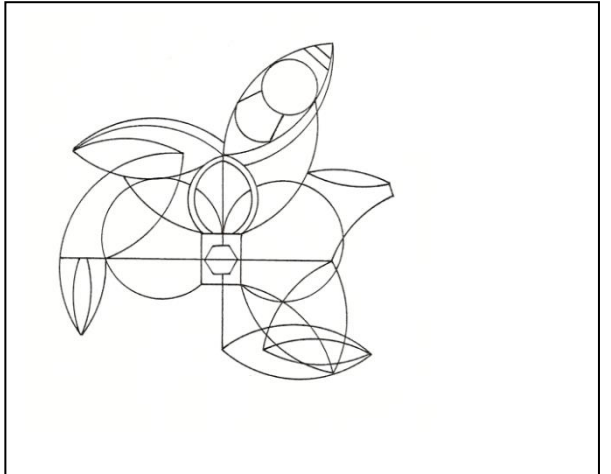

010. Dwc1971-010-a

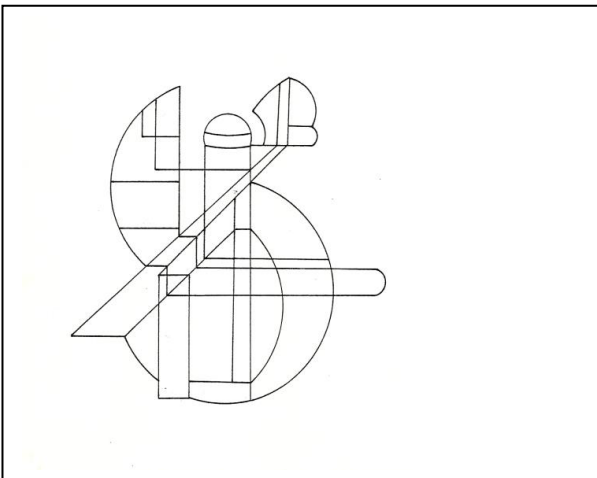

011. dwc1971-011-a

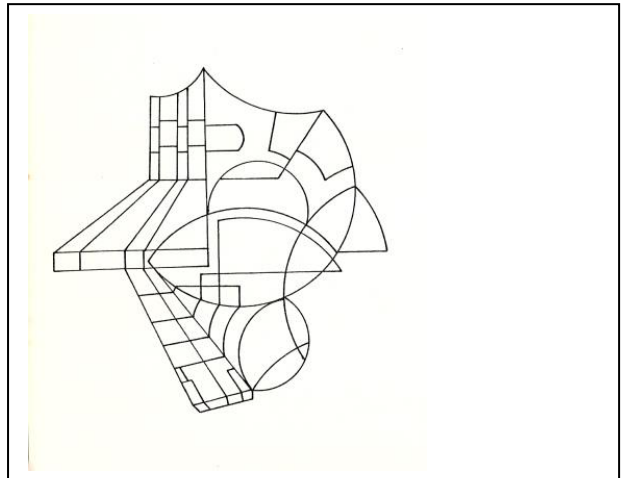

012. Dwc1971-012-a

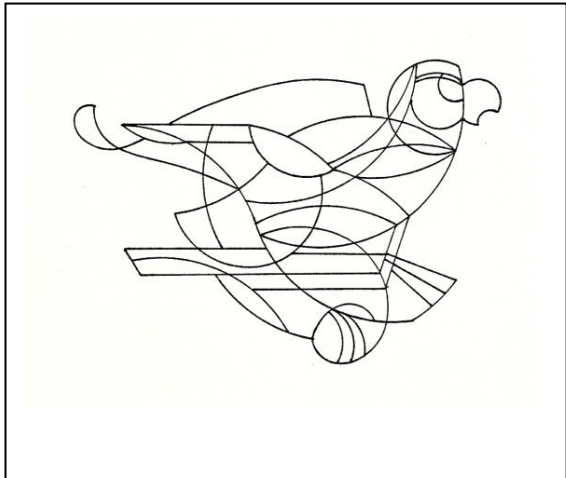

013. dwc1971-013-a

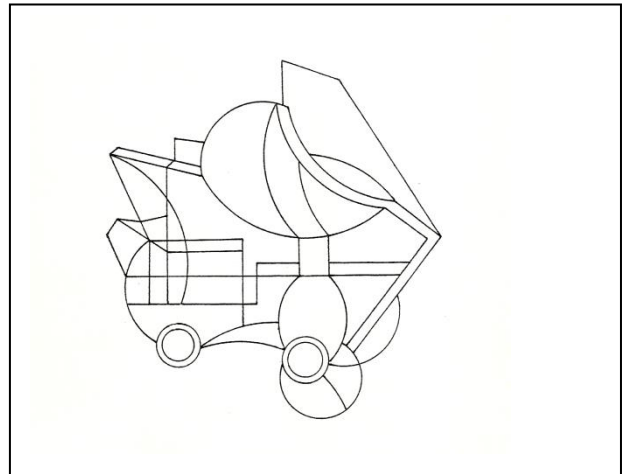

014. Dwc1971-014-a

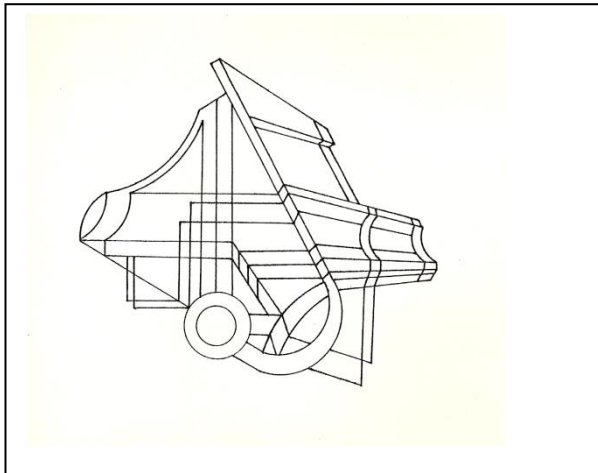

015. dwc1971-015-a

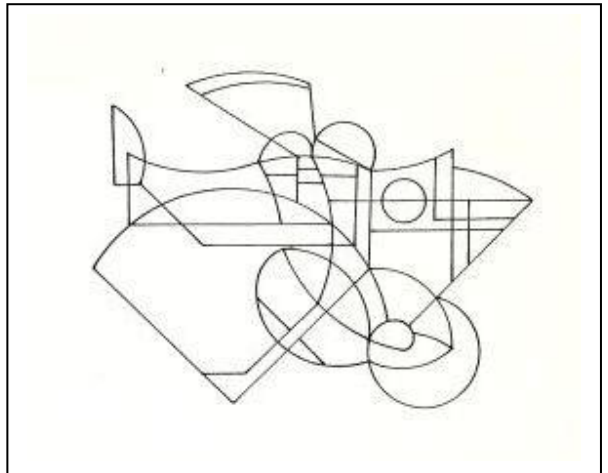

016. Dwc1971-016-a

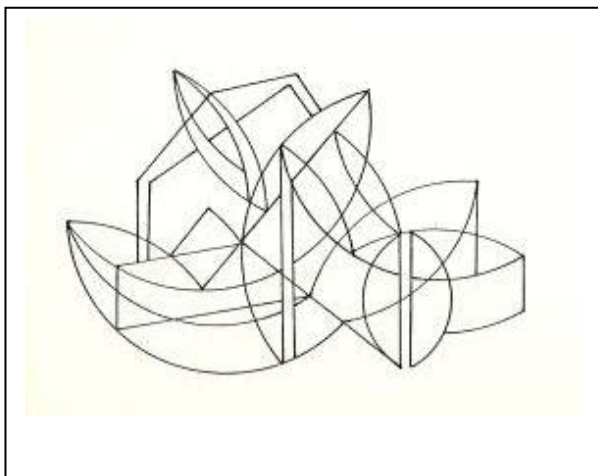

017. dwc1971-017-a

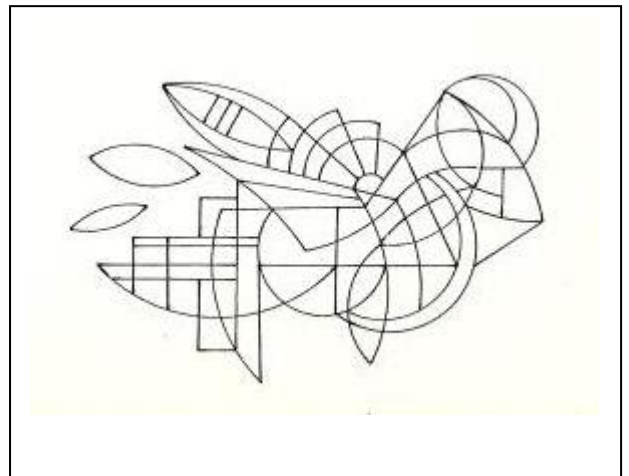

018. Dwc1971-018-a



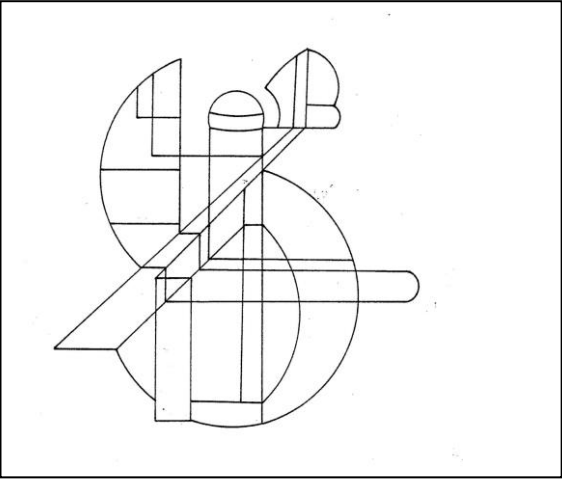

019. dwc1971-020-a

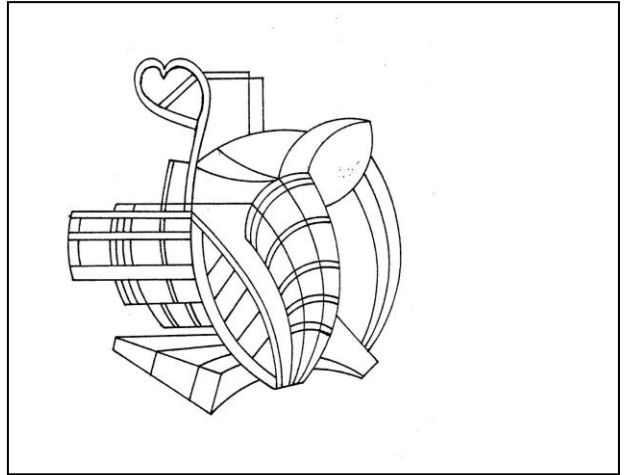

020. Dwc1971-021-a

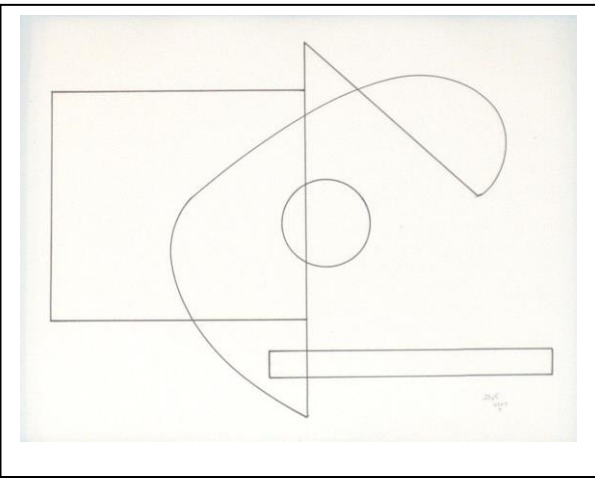

021. dwc2000-001-a

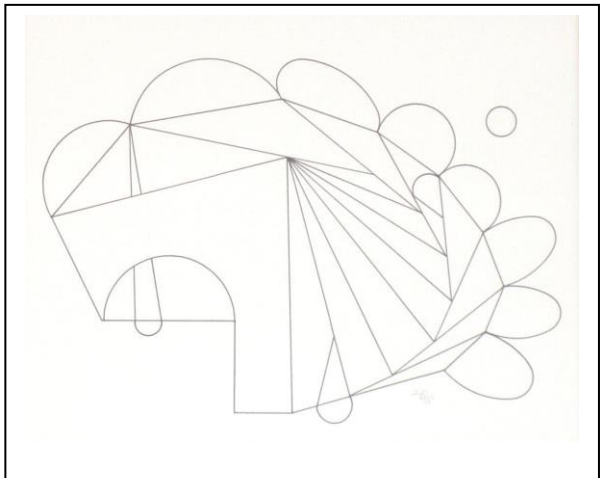

022. dwc2000-002-a

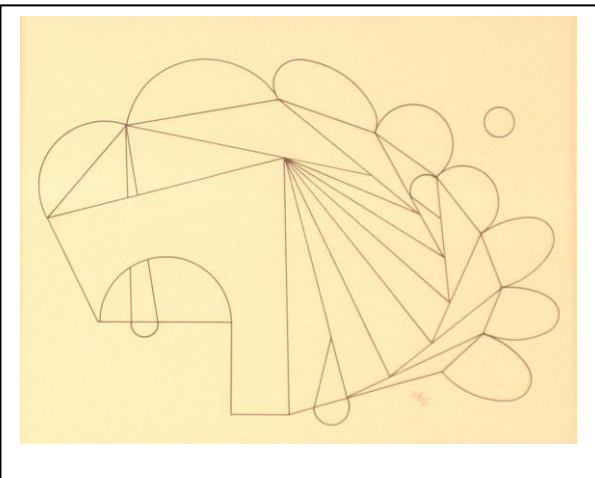

023. dwc2000-003-a

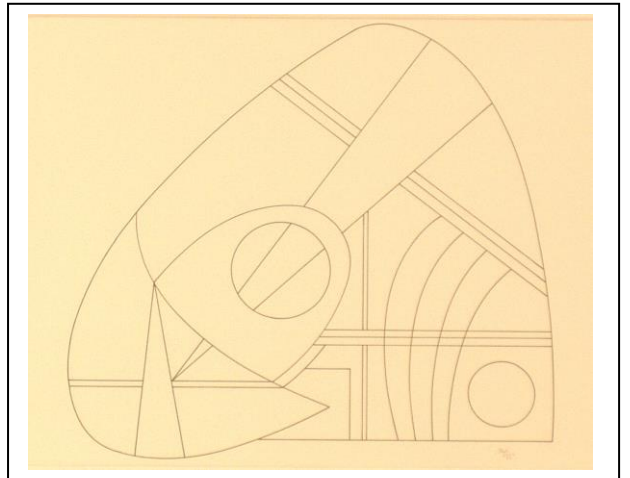

024. dwc2000-004-a

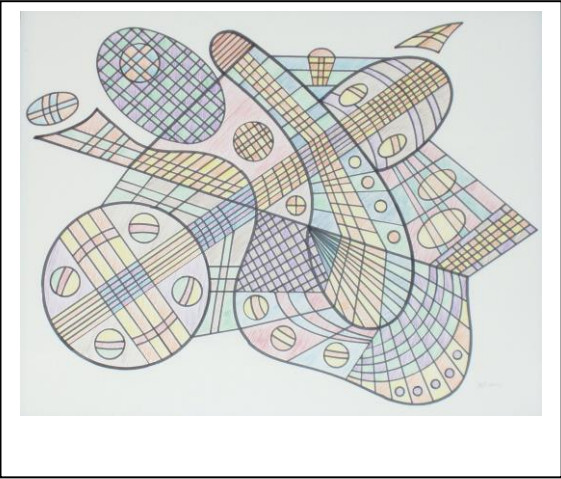

025. dwc2000-005-a

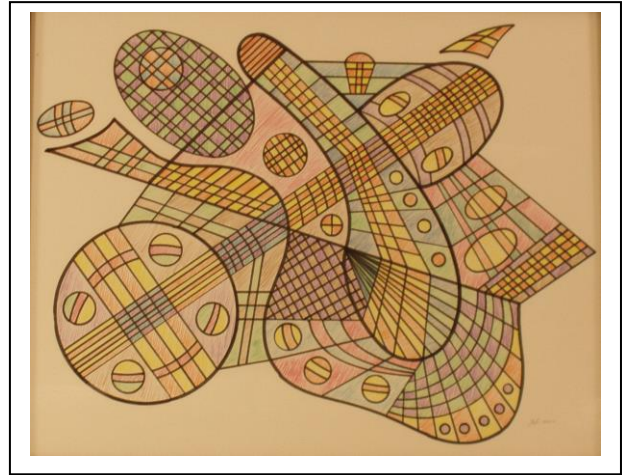

026. dwc2000-006-a

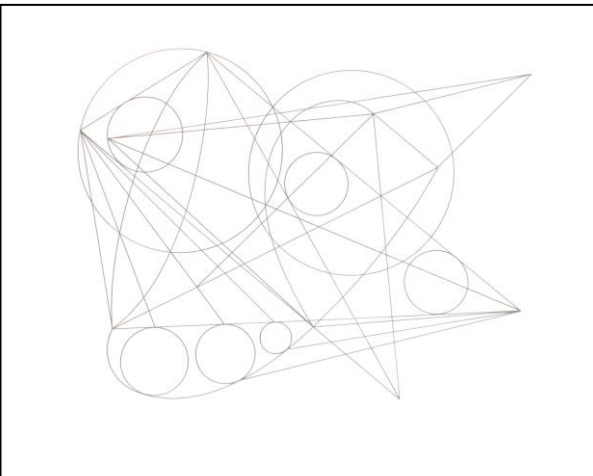

027. dwc2000-007-a

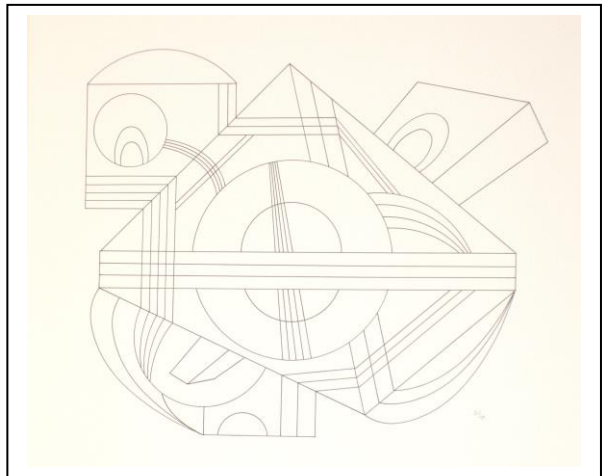

028. dwc2000-008-a

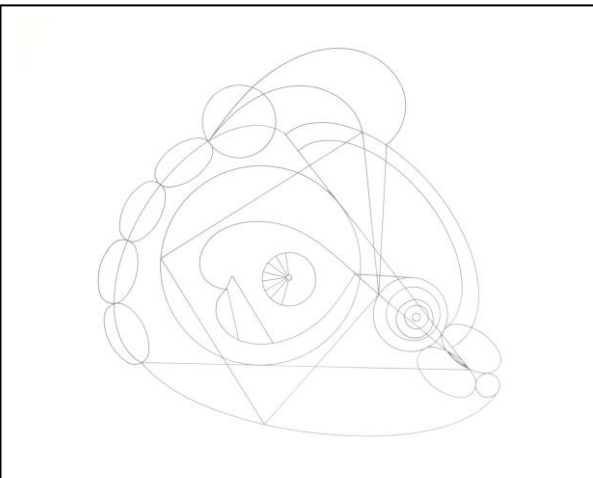

029. dwc2000-009-a

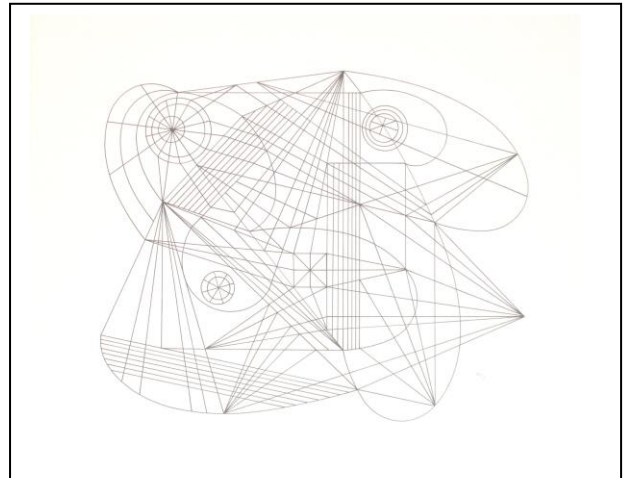

030. dwc2000-010-a

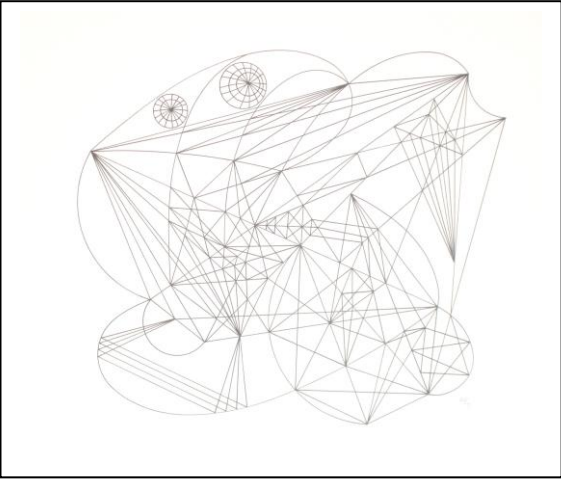

031. dwc2000-011-a

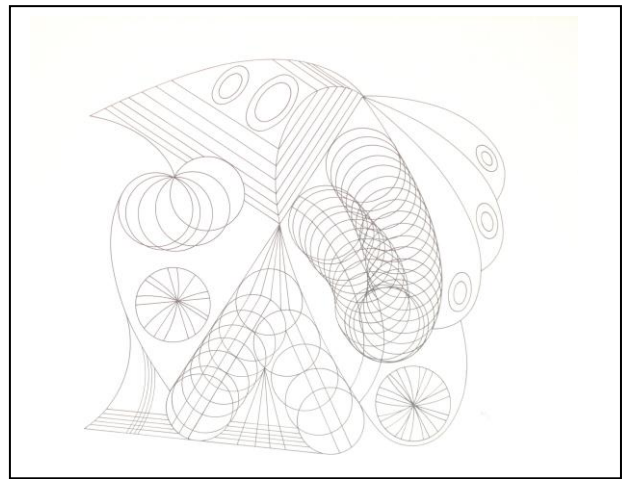

032. dwc2000-012-a

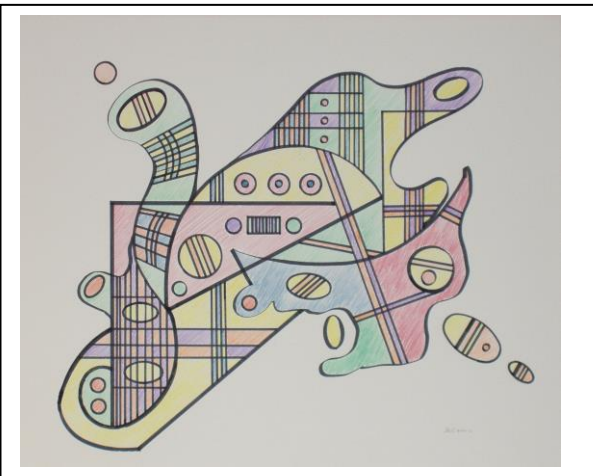

033. dwc2000-013-a

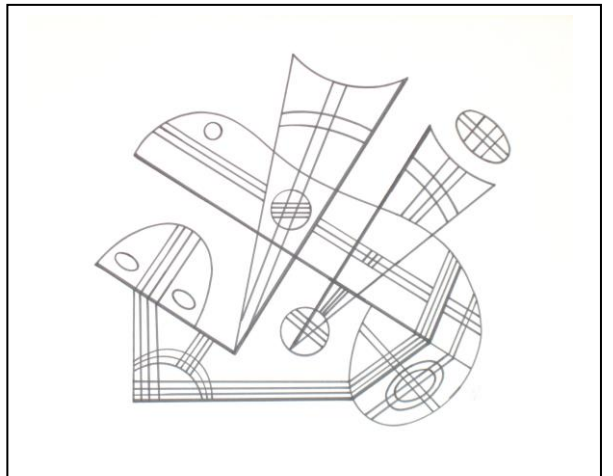

034. dwc2000-014-a

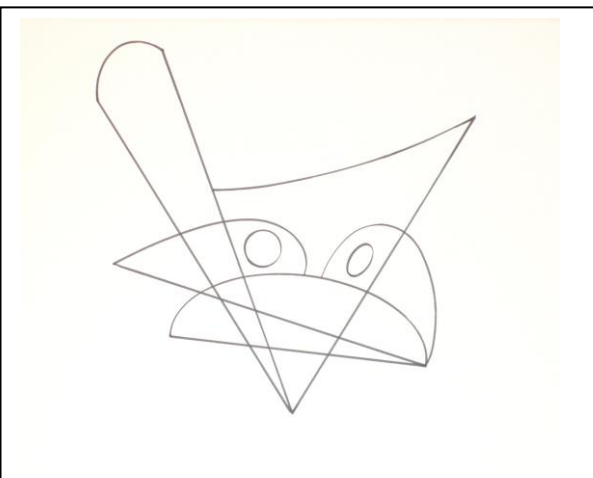

035. dwc2000-015-a

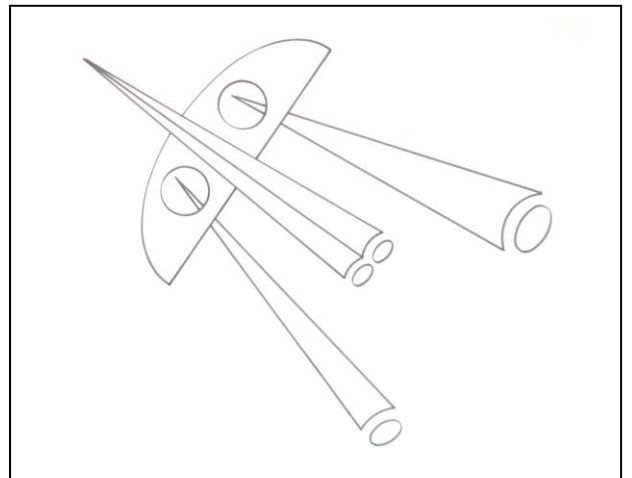

036. dwc2000-016-a

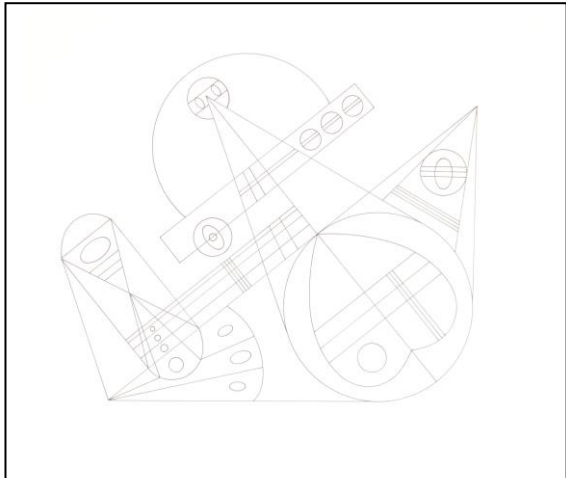

037. dwc2000-017-a

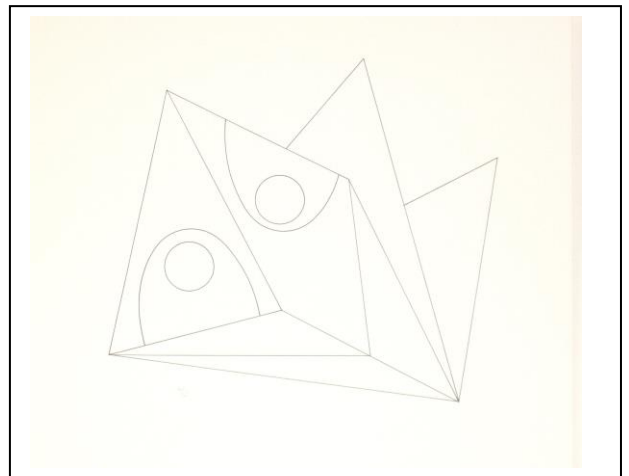

038. dwc2000-018-a

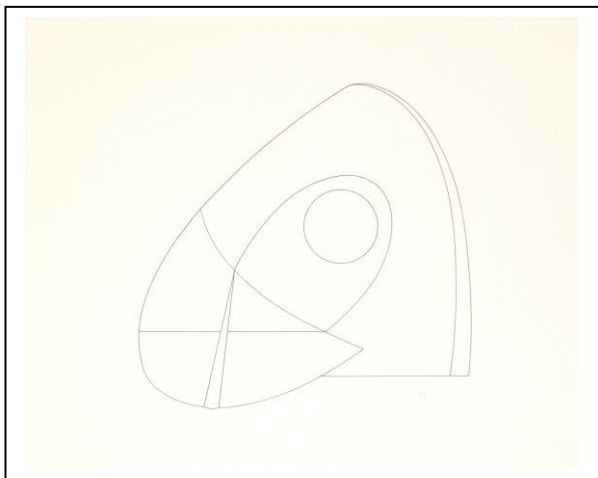

039. dwc2000-019-a

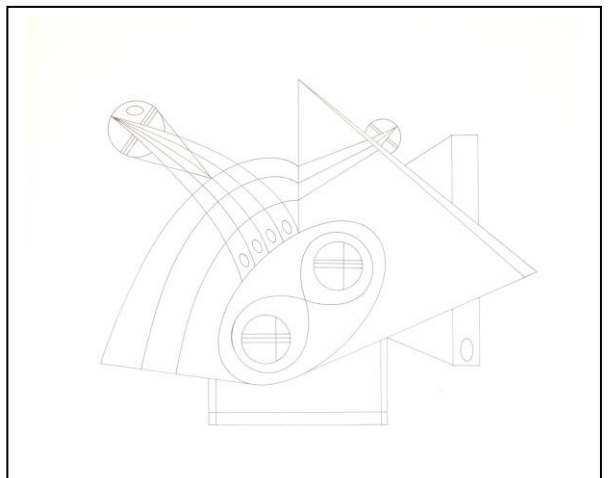

040. dwc2000-020-a

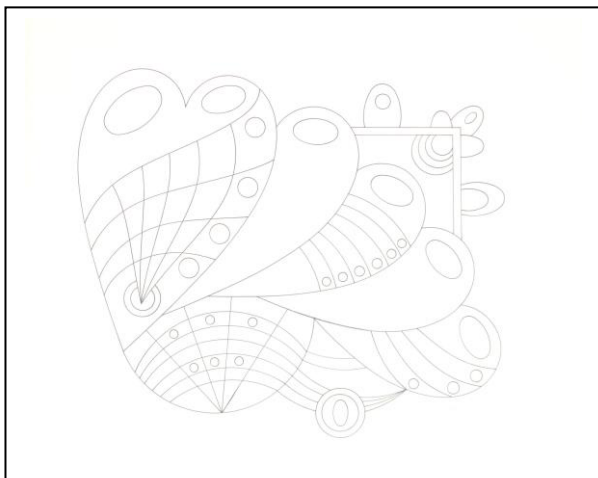

041. dwc2000-021-a

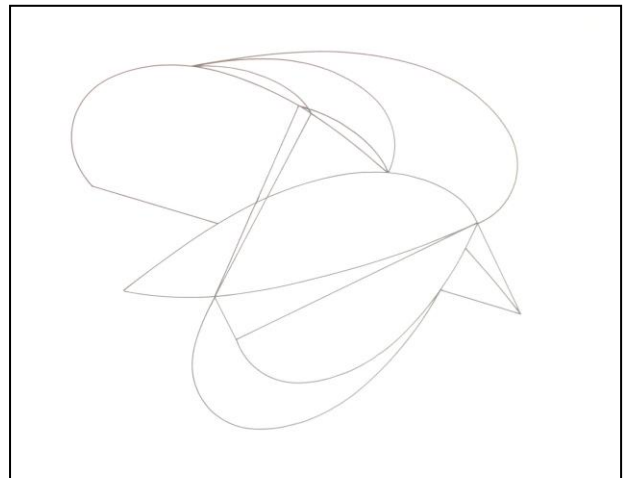

042. dwc2000-022-a

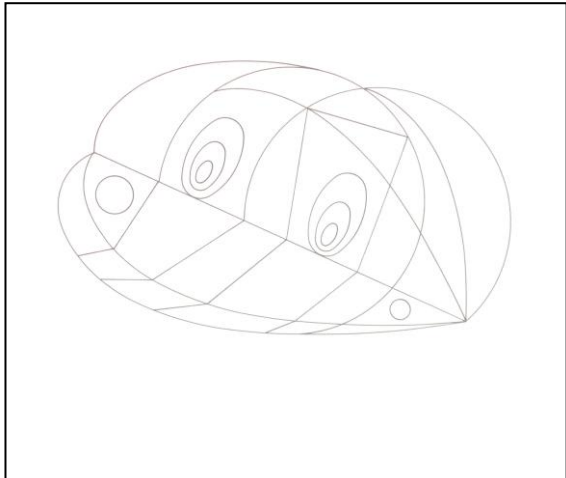

043. dwc2000-023-a

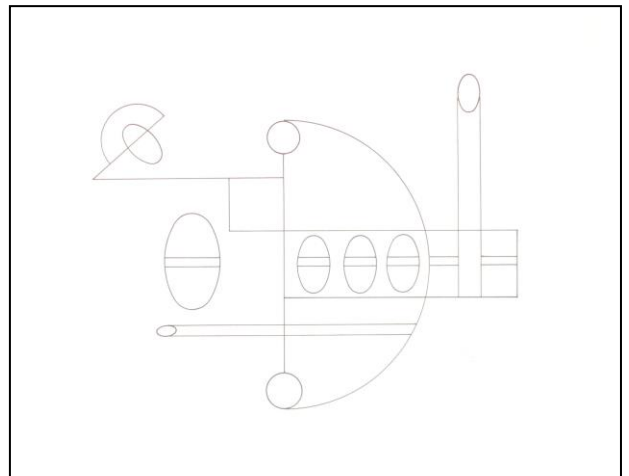

044. dwc2000-024-a

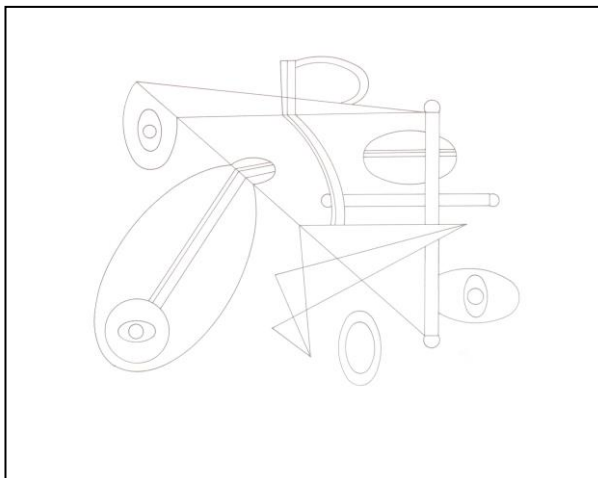

045. dwc2000-025-a

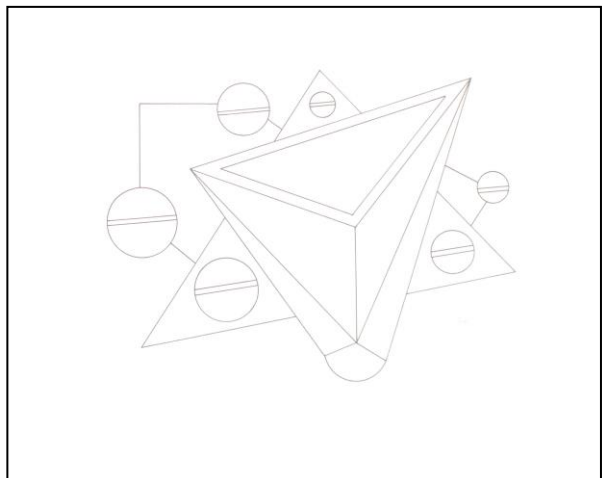

046. dwc2000-026-a

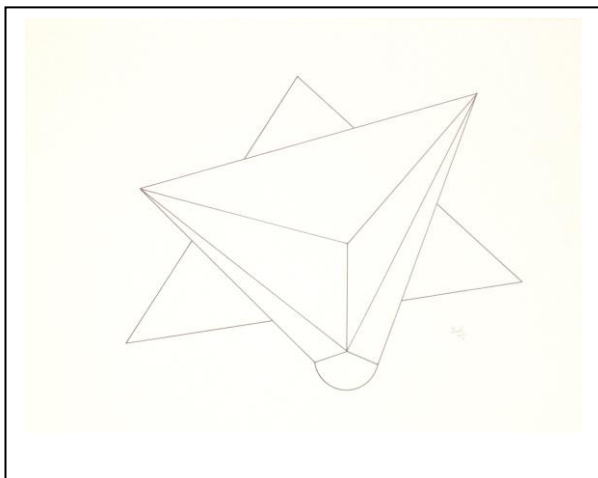

047. dwc2000-027-a

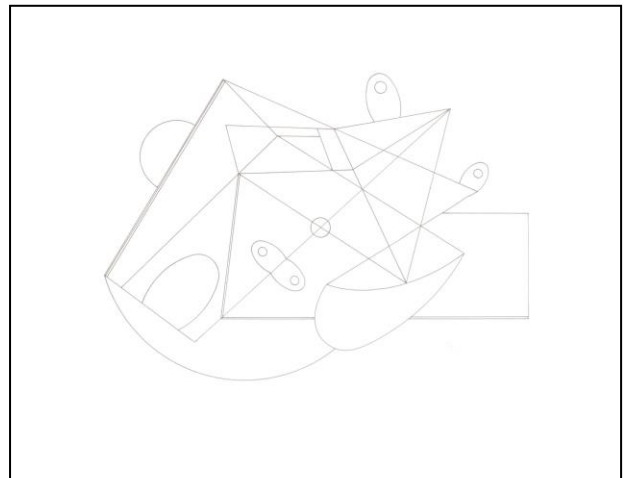

048. dwc2000-028-a

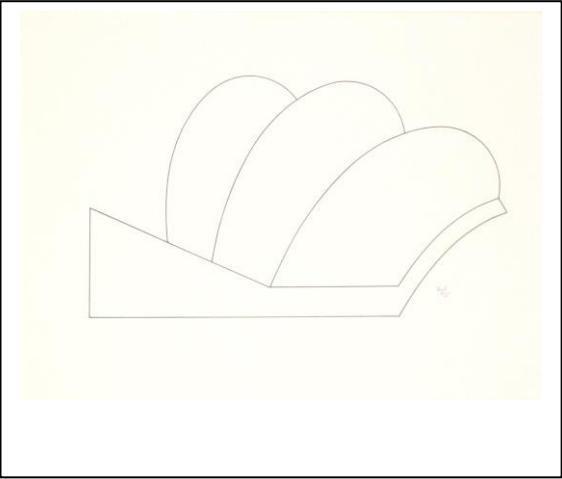

049. dwc2000-029-a

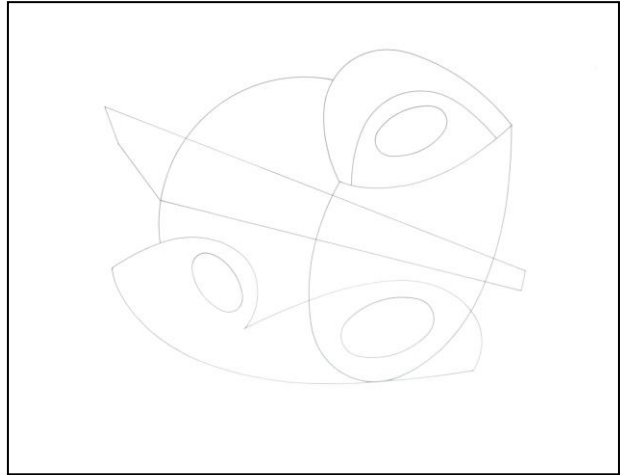

050. dwc2000-030-a

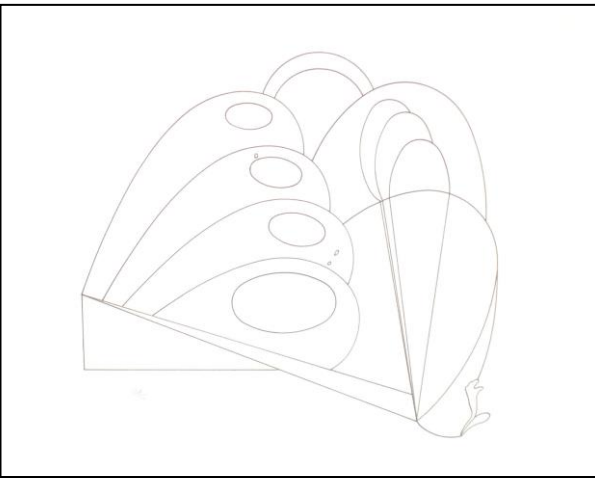

051. dwc2000-031-a

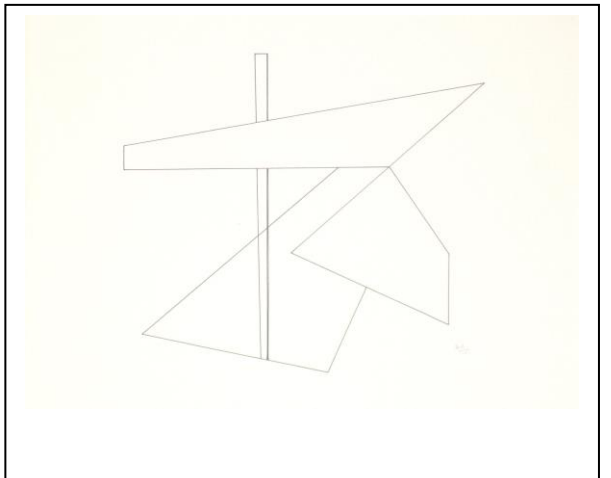

052. dwc2000-032-a

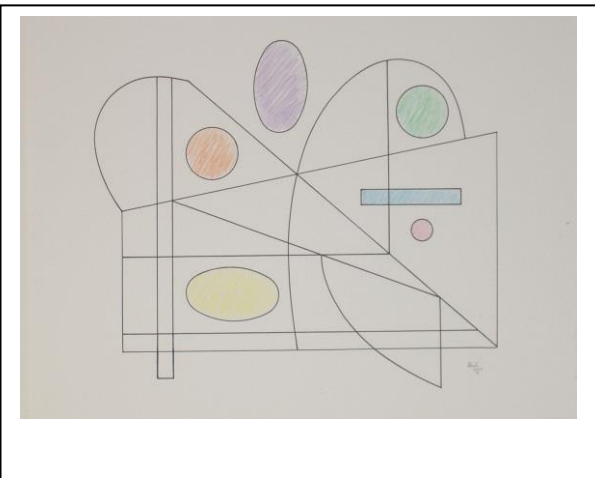

053. dwc2000-033-a

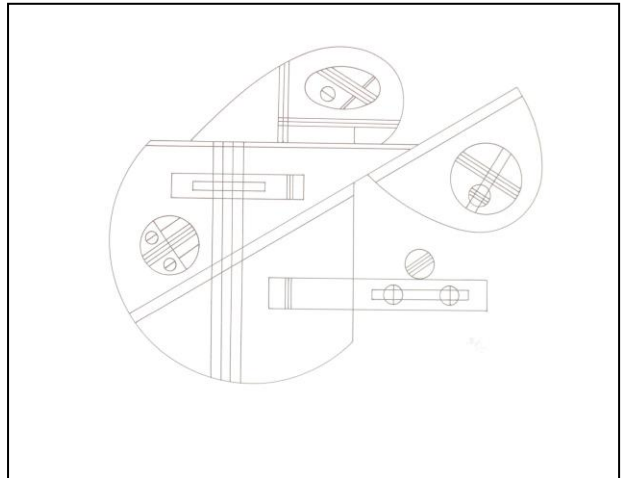

054. dwc2000-034-a

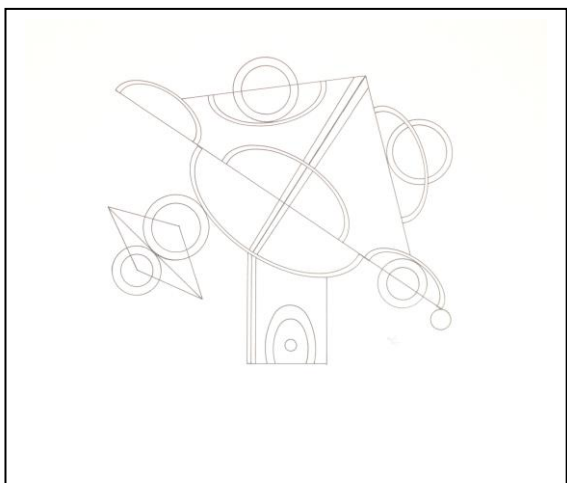

055. dwc2000-035-a

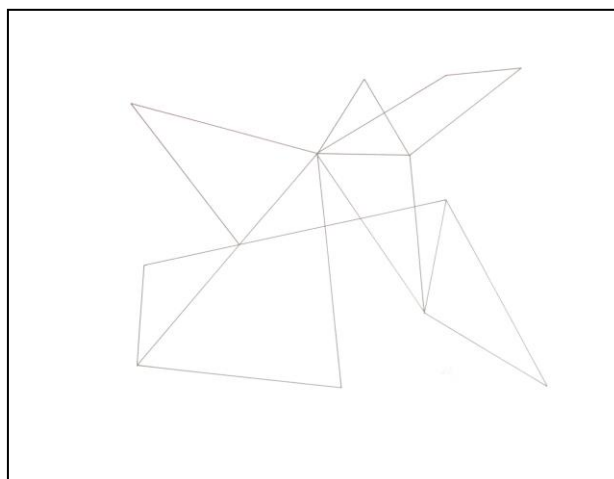

056. dwc2000-036-a

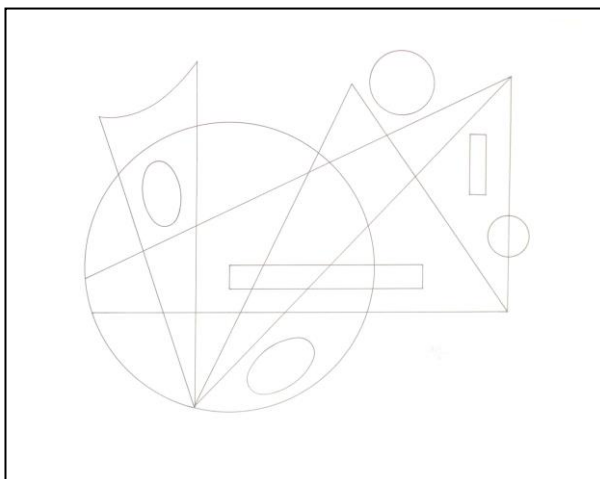

057. dwc2000-037-a

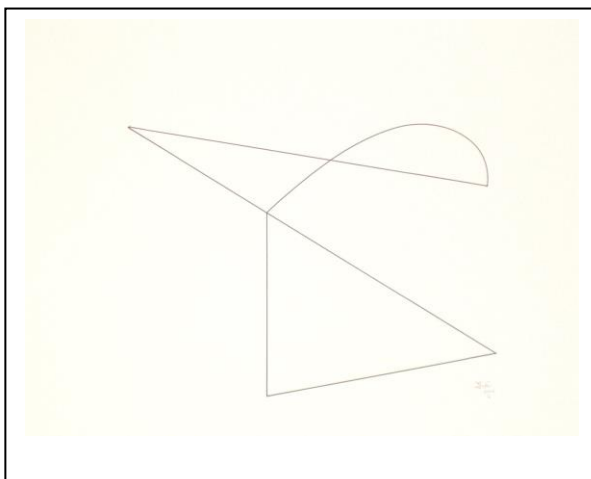

058. dwc2000-038-a

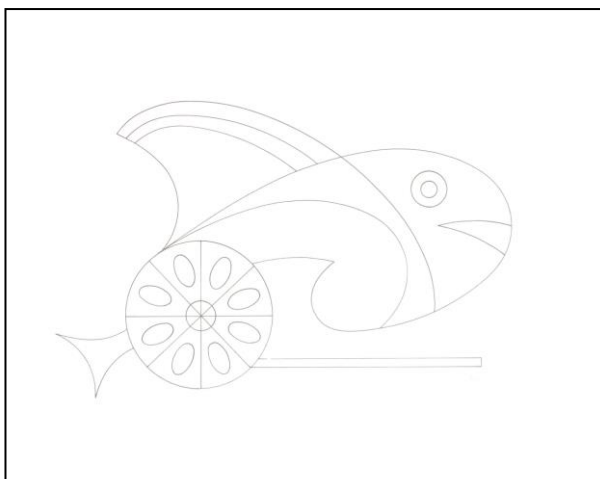

059. dwc2000-039-a

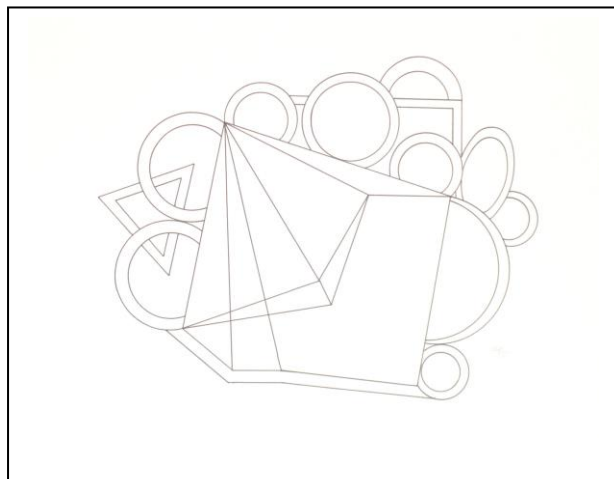

060. dwc2000-040-a

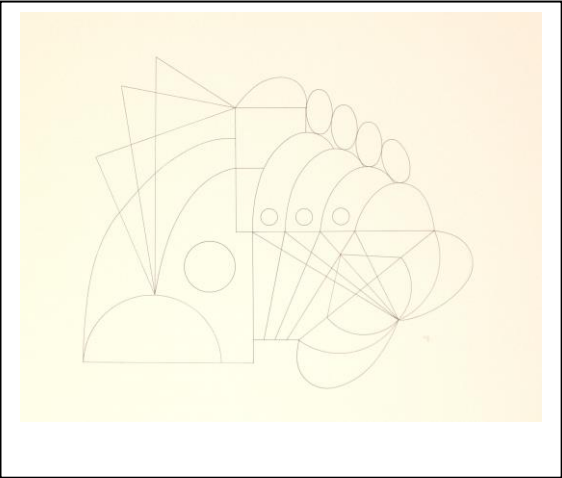

061. dwc2000-041-a

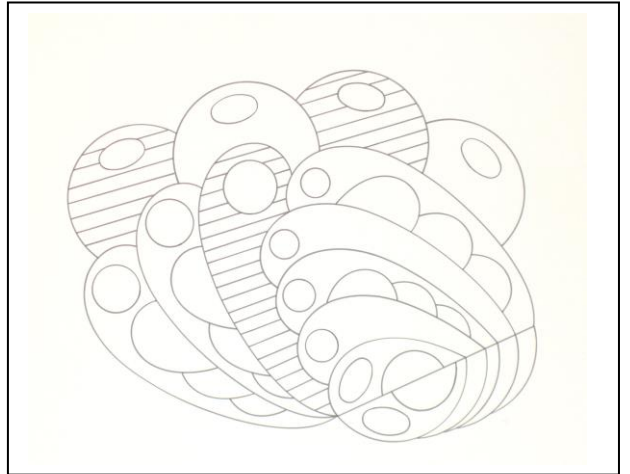

062. dwc2000-042-a

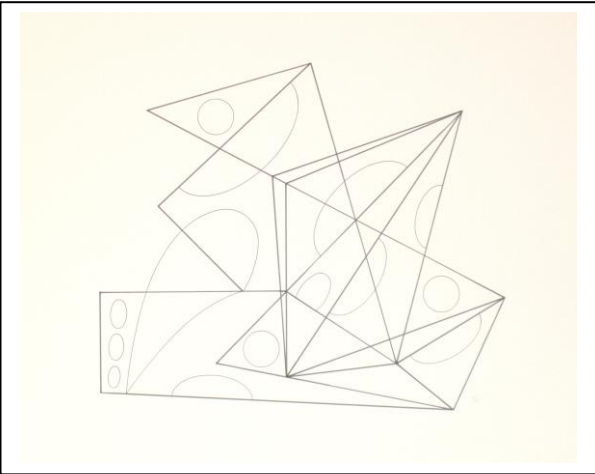

063. dwc2000-043-a

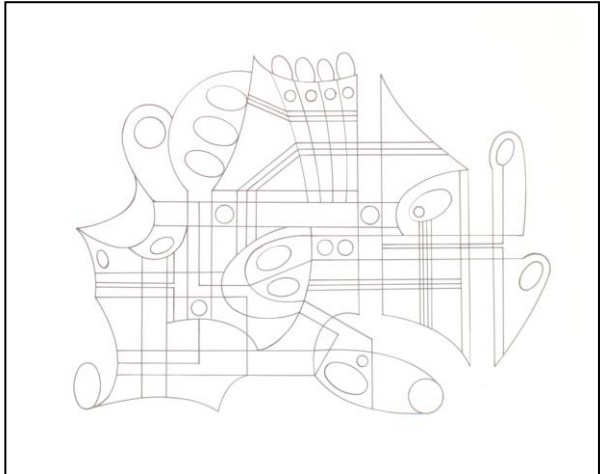

064. dwc2000-044-a

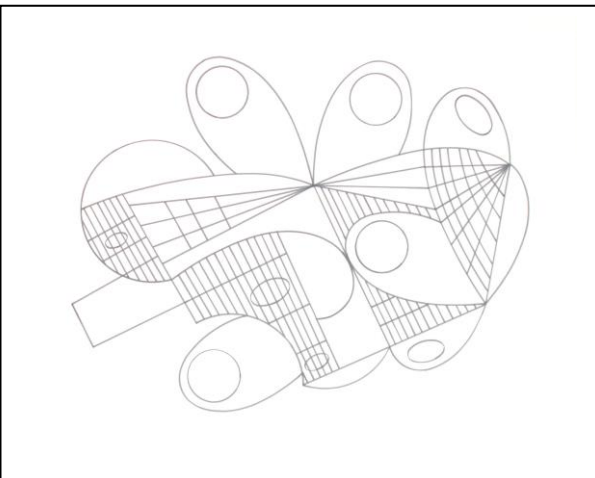

065. dwc2000-045-a

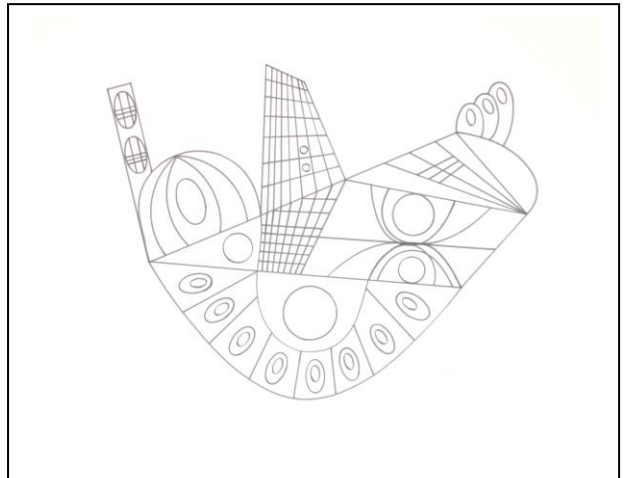

066. dwc2000-046-a



## PASTELS

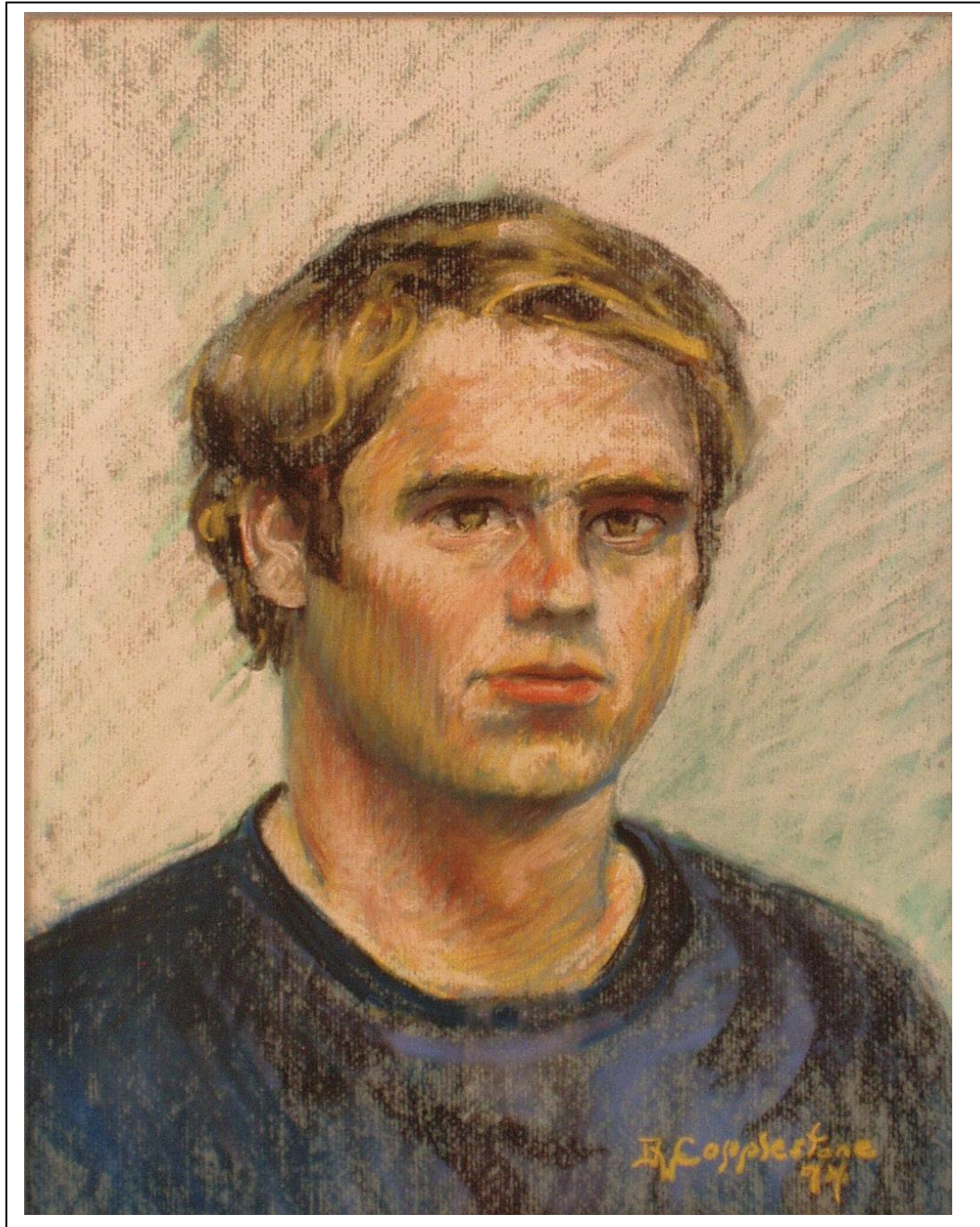

150. Self Portrait 1974

Time stays long enough for anyone who will use it.  
[Leonardo da Vinci](#)

## PASTEL DESIGNS



158.

**BENJAMIN FRANKLIN:**

They who would give up an essential liberty for temporary security, deserve neither liberty or security

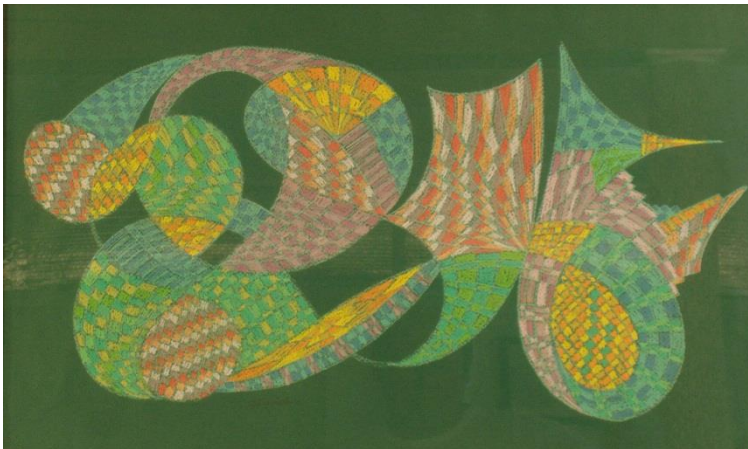

159.

**ANNE MORROW LINDBERGH:**

Him that I love, I wish to be free -- even from me.

Freedom Quotes

From Wisdom Quotes: Quotations to inspire and challenge - by Jone Johnson Lewis  
[wisdomquotes.com/cat\\_freedom.html](http://wisdomquotes.com/cat_freedom.html)



160.

**ALBERT EINSTEIN:**

All

religions, arts and sciences are branches of the same tree. All these aspirations are directed toward ennobling man's life, lifting it from the sphere of mere physical existence and leading the individual towards freedom.



161.

**ALDOUS HUXLEY:**

Your true traveller finds boredom rather agreeable than painful. It is the symbol of his liberty - his excessive freedom. He accepts his boredom, when it comes, not merely philosophically, but almost with pleasure.



162.

**BARBARA EHRENREICH:**

That's free enterprise, friends: freedom to gamble, freedom to lose. And the great thing -- the truly democratic thing about it -- is that you don't even have to be a player to lose.



163.

**C. WRIGHT MILLS:**

Freedom is not merely the opportunity to do as one pleases; neither is it merely the opportunity to choose between set alternatives. Freedom is, first of all, the chance to formulate the available choices, to argue over them -- and then, the opportunity to choose.

Line in **Balance**

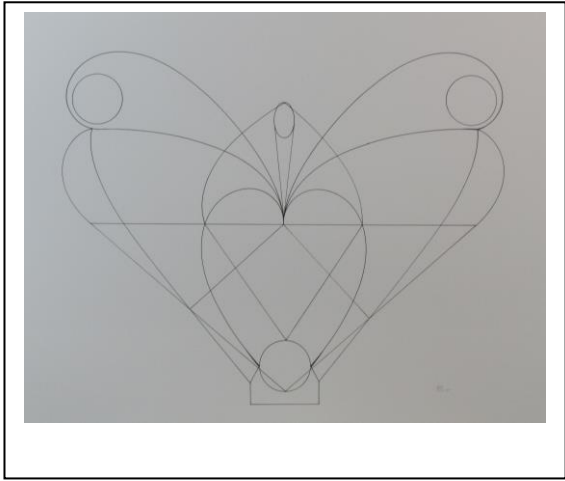

001. dwc2015-024b

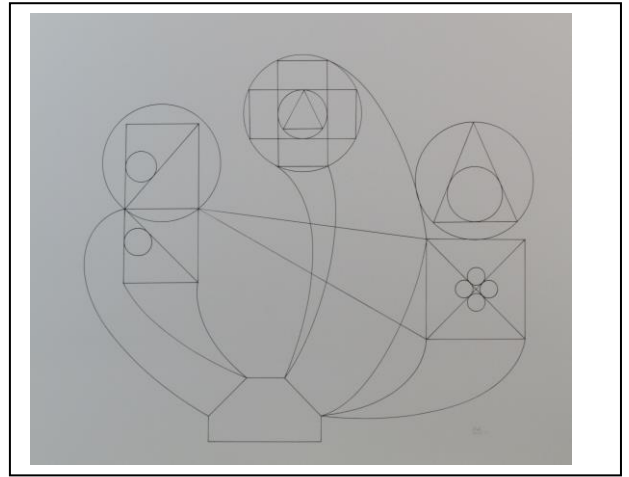

002. dwc2015-023b

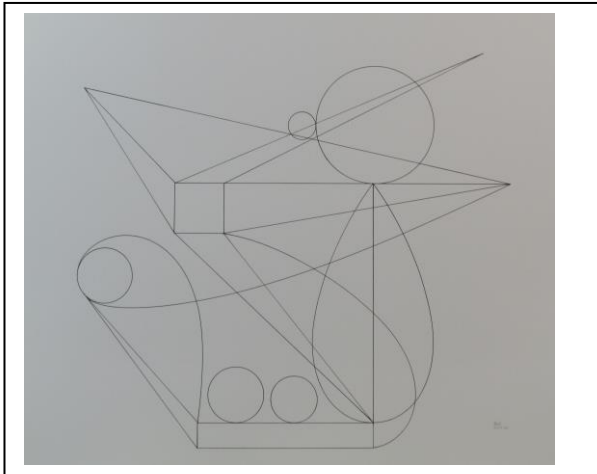

003. dwc2015-026b

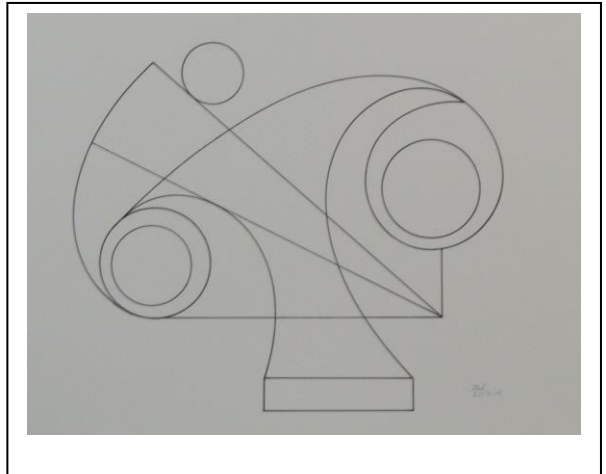

004. dwc2015-019b

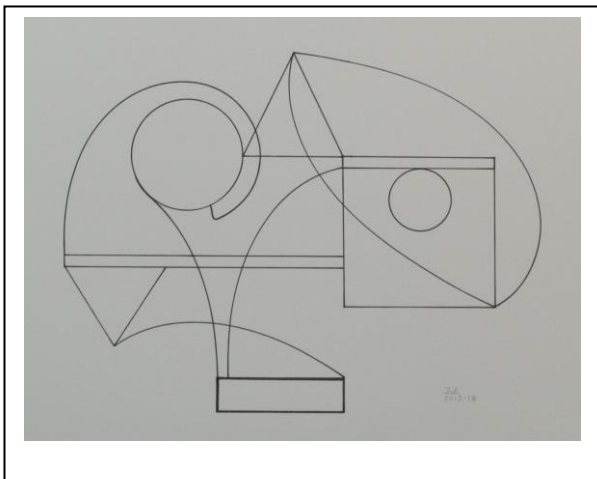

005. dwc2015-018b

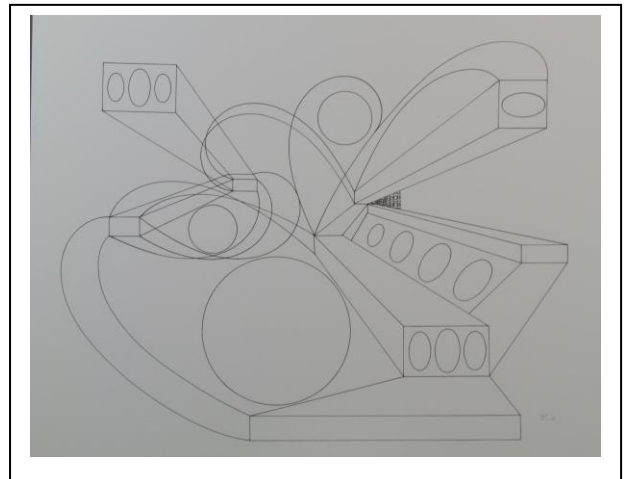

006. dwc2015-017b

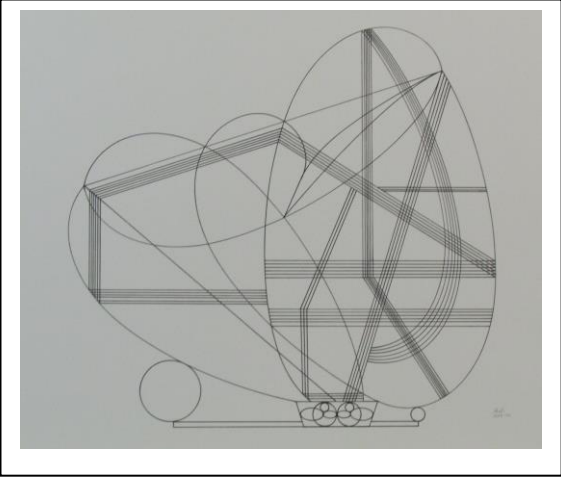

007. dwc2015-012-b

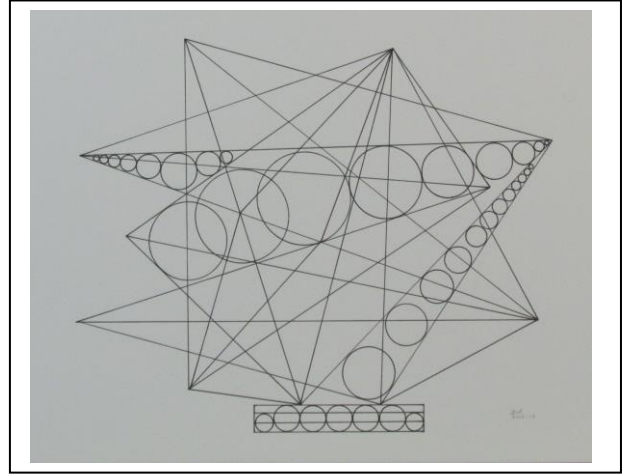

008. dwc2015-013b

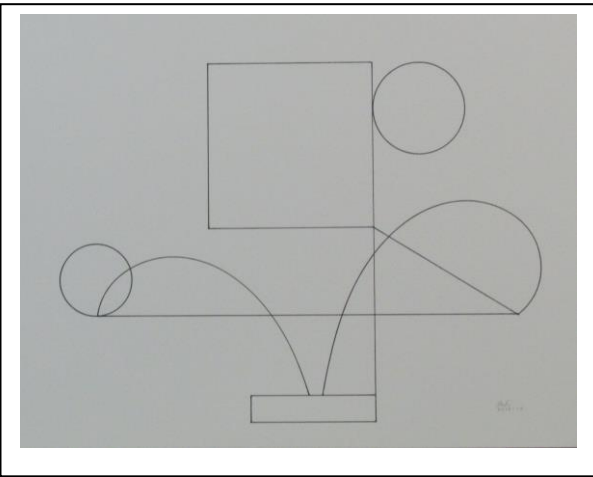

009. dwc2015-014b

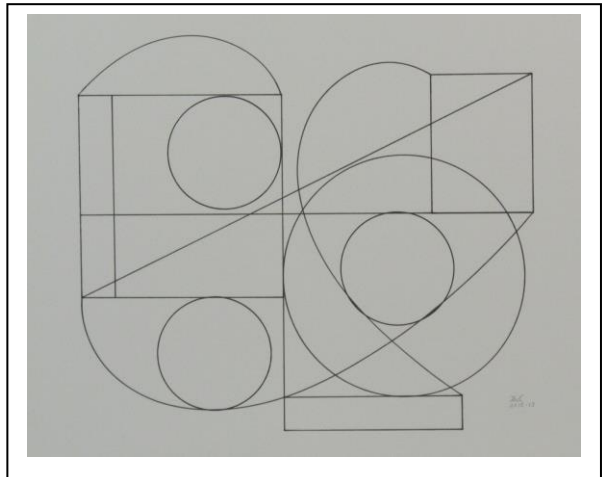

010. dwc2015-015b

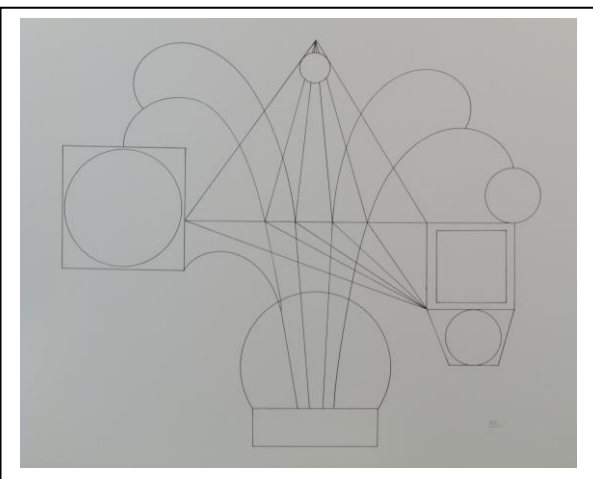

011. dwc2015-016b

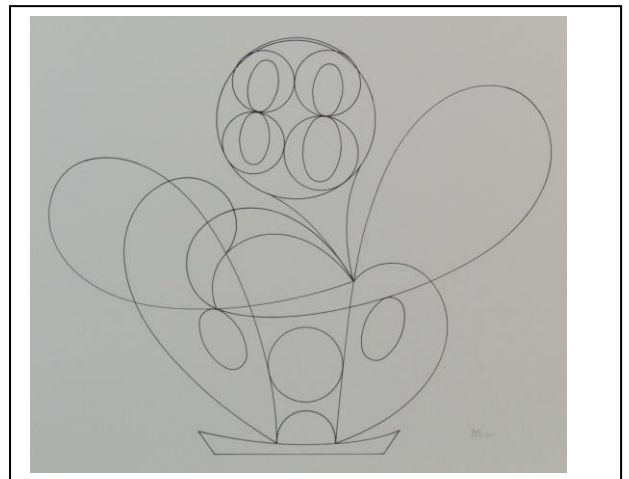

012. dwc2015-020b

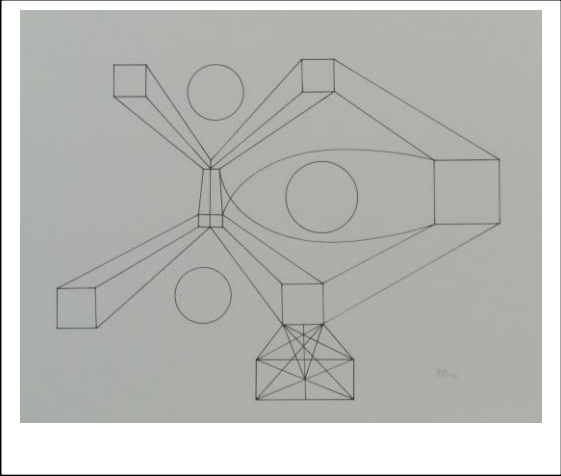

013. dwc2015-021b

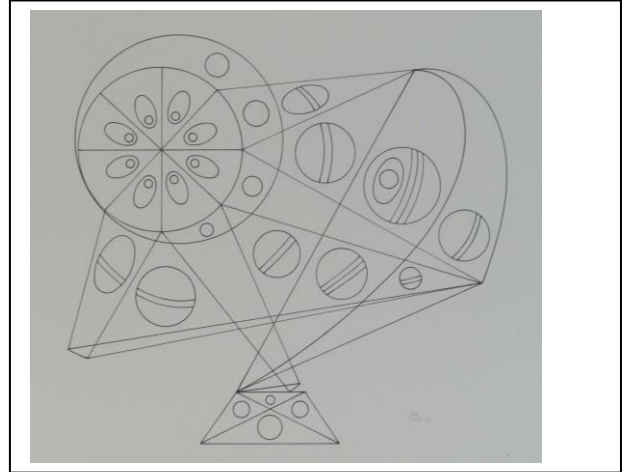

014. dwc2015-022b

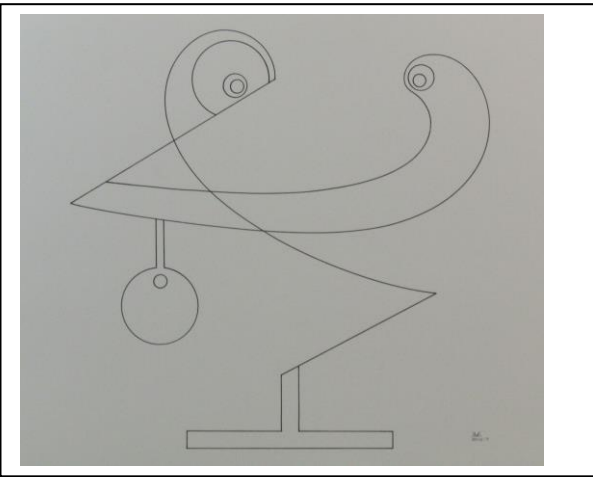

015. dwc2015-007-b

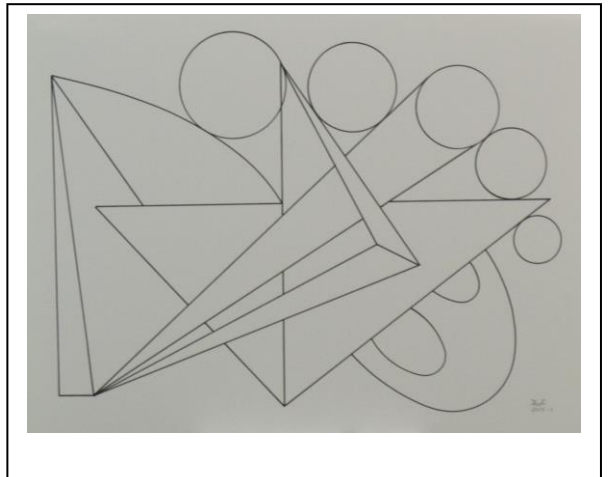

016. dwc2015-001-b

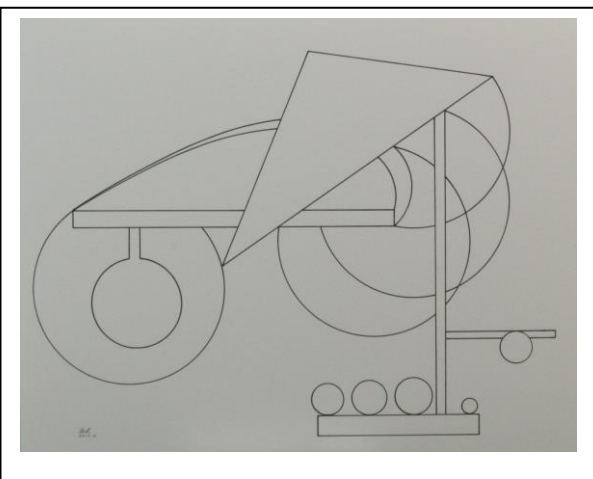

017. dwc2015-002-b

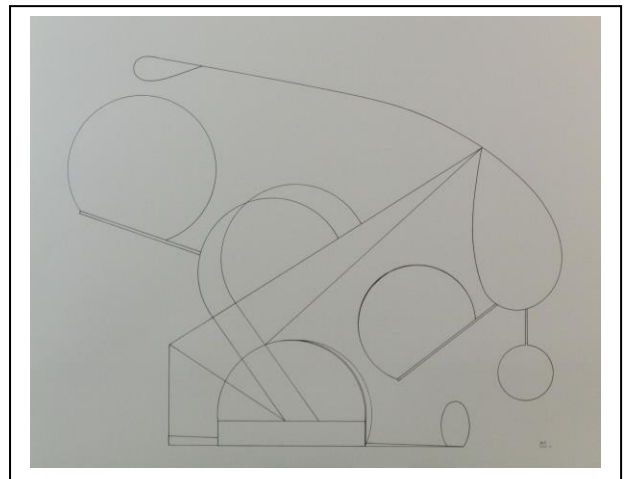

018. dwc2015-003-b

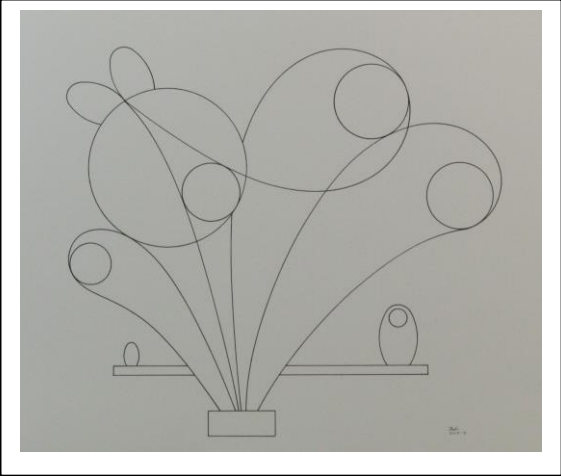

019. dwc2015-004-b

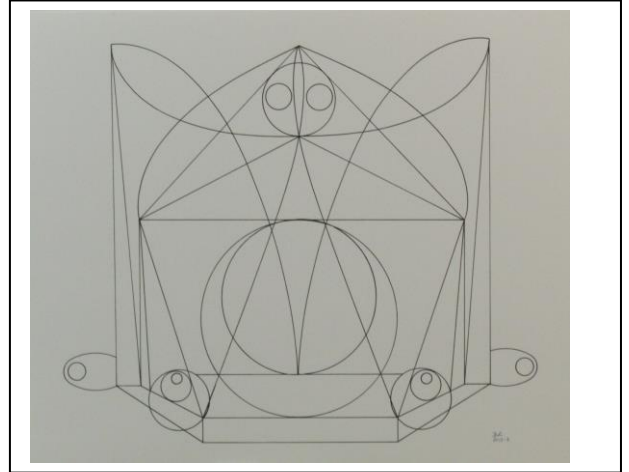

020. dwc2015-005-b

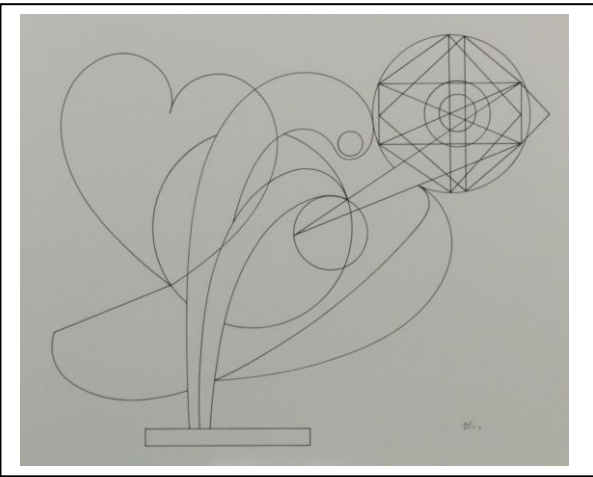

021. dwc2015-006-b

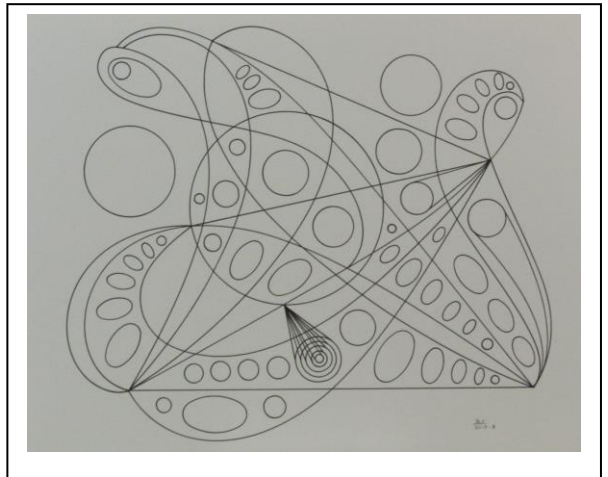

022. dwc2015-008-b

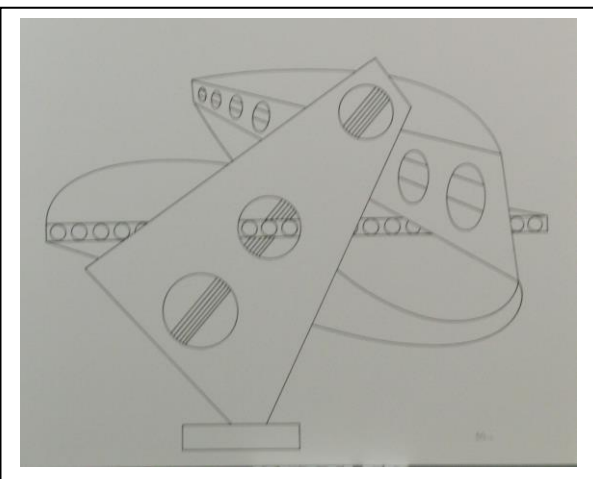

023. dwc2015-009-b

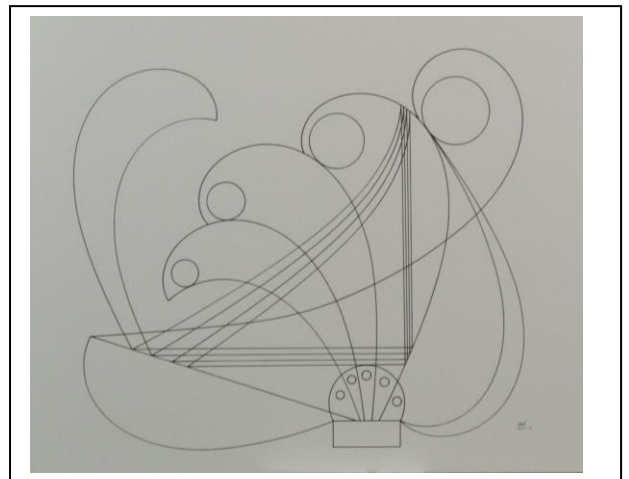

024. dwc2015-010-b



# Orbiter™

Classic Ring Toss  
Interactive Art In Motion Game



6' Orbiter



12" Orbiter

Every time an Orbiter rings  
a wish for peace takes wing!



Brainteaser / Challenging Entertainment

Peace - lack of conflict and freedom from fear.  
Serenity - the state of being calm, peaceful, and untroubled.

As Einstein once said, "One of the strongest motives that lead persons to art or science is a flight from the everyday life.... With this negative motive goes a positive one. Man seeks to form for himself, in whatever manner is suitable for him, a simplified and lucid image of the world, and so to overcome the world of experience by striving to replace it to some extent by this image. This is what the painter does, and the poet, the speculative philosopher, the natural scientist, each in his own way. Into this image and its formation, he places the center of gravity of his emotional life, in order to attain the peace and serenity that he cannot find within the narrow confines of swirling personal experience."  
Albert Einstein

# COPPLESTONE IS ALL ABOUT PASSION

**The artist David Coplestone speaks about the dreams and goals that inspired him to create.**

David W. Coplestone paints portraits, landscapes and seascapes. His painting style is fairly representational with an emphasis on color and the free choice of color. David says that he chose to be an artist because he wanted to be a part of the beauty, emotion and passion of art. He says "I am a person who believes that it's a wonderful thing when people follow their dreams. At 19 I dreamed that I would follow my passion to create and to become an artist. I didn't know when I began if my efforts would be successful or not, but I knew that I didn't want to arrive at the end of my life and wish that I had lived my life doing something that I was passionate about. I knew that I couldn't fail if my goal was to follow my dreams and create. I realized that I would probably need to make some compromises with my time to survive the struggle, but that would be fine, too.

I chose the fine art of painting because of the intense emotions that I would feel while viewing great paintings by artists I admired, and because I believed that the creative environment of the artist's studio would be the best place for me to attempt to realize my creative potential. In my studio I have silence, music, videos, books, I am free to think, sing, dance, laugh, I can take a blank canvas and on it arrange the colors that I love, and watch the image that I am envisioning develop in front of me. I believed that a life involved with so much love and passion in it would be a wonderful life. That was the dream.

I hope that when someone views a painting of mine that the colors that I have mixed and the method that I have used to apply them to the canvas inspire in the viewer the joyful feelings that motivated me to paint the subject in the first place. If a painting of mine can instill in the viewer the love of nature, the love of art, or the love for the subject of a painting that I was feeling at the time that I painted it, then I have achieved a great result. I have accomplished my goal to create, to share my passion for art and beauty, and to follow my dream."

View the works of David W. Coplestone at: [coplestoneartworks.com](http://coplestoneartworks.com) and [coplestonegames.com](http://coplestonegames.com).

Viewers can purchase decorative gifts and games that David has designed by going to his website and following this link to his Amazon page.

## Body of work

I have no special talents. I am only passionately curious."  
-Albert Einstein

Musical accompaniment by the artists father:

**Wesley Coplestone (1909 - 1983)**

FIRST SONG (2.0 Megs)

SECOND SONG (1.8 Megs)

**Email: [rtcreation@verizon.net](mailto:rtcreation@verizon.net)**

# COPPLESTONE

A BODY OF WORK  
10/24/2020

By:

David Wesley Coplestone  
Wellesley, MA 02482

All reproductions from the archives of David Coplestone.

Made in USA.

<http://coplestonegames.com/>  
<http://coplestoneartworks.com/>  
<http://www.facebook.com/coplestonellc>  
<http://www.youtube.com/user/orbiterringtoss>  
Twitter  
Amazon

Copyright © 2015 All Rights Reserved,  
David Coplestone, Wellesley, MA 02482.



A body of work by David W. Coplestone  
To create, to entertain.

I HAVE ADDED MANY FAMOUS QUOTES BY VARIOUS WRITERS TO GO ALONG WITH THE PAGES OF MY PAINTINGS.

Many quotes that I have posted here can be found in the book Artists on Art from X1V to the XX Century edited by Robert Goldwater and Marco Treves

You cannot define talent. All you can do is build the greenhouse and see if it grows.  
-William P. Steven

As Einstein once said, "One of the strongest motives that lead persons to art or science is a flight from the everyday life.... With this negative motive goes a positive one. Man seeks to form for himself, in whatever manner is suitable for him, a simplified and lucid image of the world, and so to overcome the world of experience by striving to replace it to some extent by this image. This is what the painter does, and the poet, the speculative philosopher, the natural scientist, each in his own way.

Into this image and its formation, he places the center of gravity of his emotional life, in order to attain the peace and serenity that he cannot find within the narrow confines of swirling personal experience."

Albert Einstein

A work in progress.

Some might have advised me to pursue a more conventional career and not to spend so much of my time, energy and resources creating the artwork and games contained in this book. Others might believe that the material in this book is evidence of time well spent. I did not feel that I had a choice. I was answering a calling, following a dream. So whether you think I made the right choice or not, as Robert Frost said: Two roads diverged in a wood. I took the one less traveled by and that has made all the difference.

A lifetime of;  
HOPES, THOUGHTS, DREAMS, and IDEAS

Robert Frost (1874–1963). Mountain Interval. 1920.

### 1. The Road Not Taken

TWO roads diverged in a yellow wood,  
And sorry I could not travel both  
And be one traveler, long I stood  
And looked down one as far as I could  
To where it bent in the undergrowth; 5

Then took the other, as just as fair,  
And having perhaps the better claim,  
Because it was grassy and wanted wear;  
Though as for that the passing there  
Had worn them really about the same, 10

And both that morning equally lay  
In leaves no step had trodden black.  
Oh, I kept the first for another day!  
Yet knowing how way leads on to way,  
I doubted if I should ever come back. 15

I shall be telling this with a sigh  
Somewhere ages and ages hence:  
Two roads diverged in a wood, and I—  
I took the one less traveled by,  
And that has made all the difference. 20